

The Rules of the Road

Navigation Rules and Regulations Handbook

Department of
Homeland Security
**United States
Coast Guard**



Navigation Rules and Regulations Handbook

- Containing – International and Inland Rules of the Road
and their respective Annexes
- Bridge-to-Bridge Radiotelephone Regulations
 - Vessel Traffic Management Regulations
 - Other pertinent regulations for waterway users

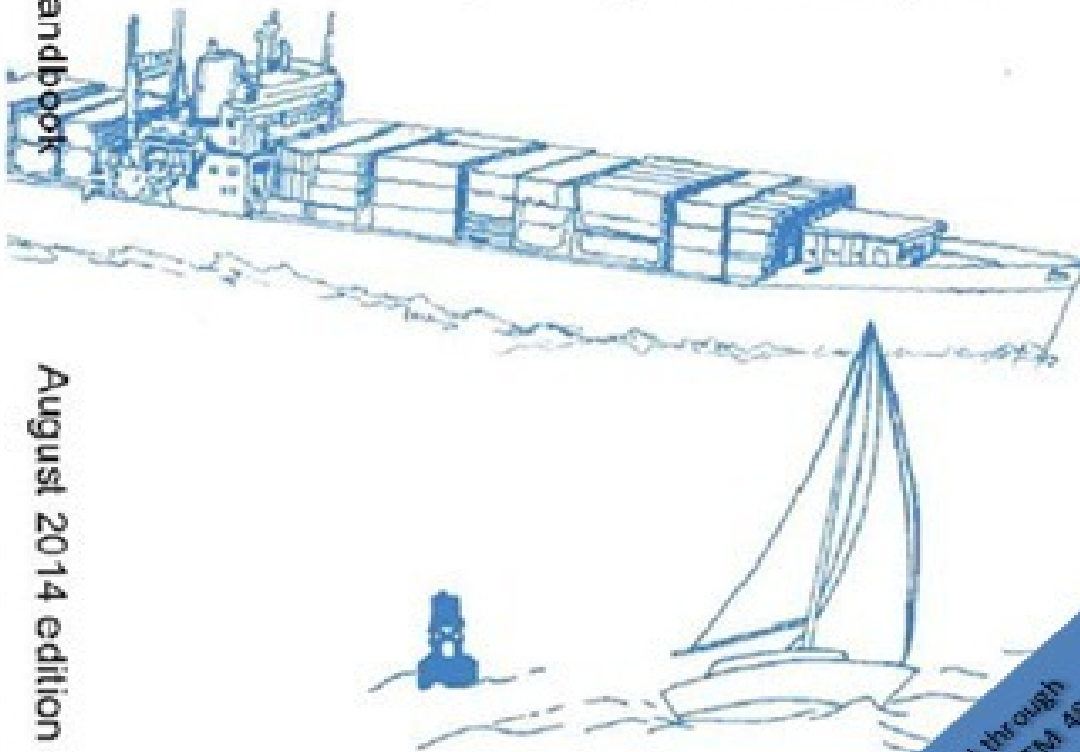

August 2014 edition

Corrected through
LNM 46-14 / NTM 48-14
Nov. 22nd 2014



NAVIGATION RULES
INTERNATIONAL—INLAND

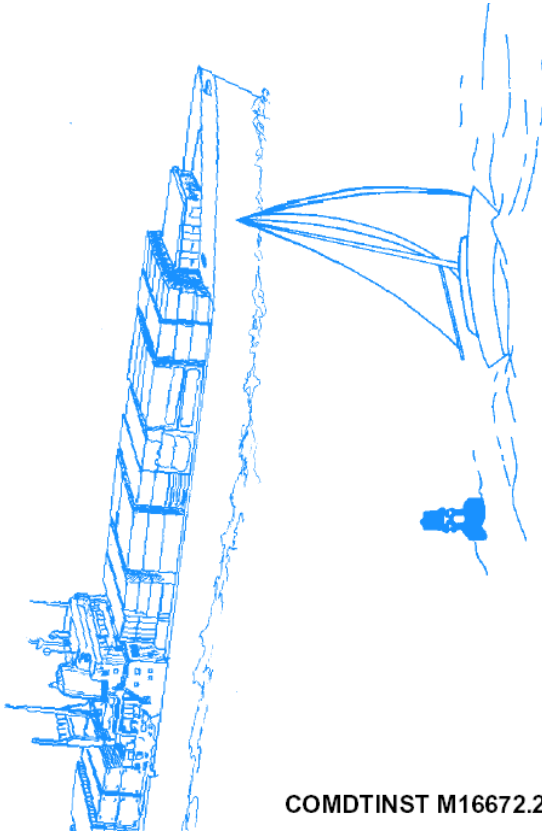

CONTENTS

INTRODUCTION iv

LEGAL CITATIONS vi

CONVERSION TABLE..... vii

NAVIGATION RULES 1

PART A—GENERAL..... 2

 RULE 1 Application..... 2

 RULE 2 Responsibility 6

 RULE 3 General Definitions..... 6

PART B—STEERING AND SAILING RULES..... 12

 Section I—Conduct of Vessels in Any Condition of Visibility 12

 RULE 4 Application..... 12

 RULE 5 Look-out 12

 RULE 6 Safe Speed 14

 RULE 7 Risk of Collision..... 16

 RULE 8 Action to Avoid Collision 18

 RULE 9 Narrow Channels 20

 RULE 10 Traffic Separation Schemes 22

 Section II—Conduct of Vessels in Sight of One Another 26

 RULE 11 Application..... 26

 RULE 12 Sailing Vessels..... 26

 RULE 13 Overtaking..... 28

 RULE 14 Head-on Situation 30

 RULE 15 Crossing Situation 30

 RULE 16 Action by Give-way Vessel 32

 RULE 17 Action by Stand-on Vessel 32

 RULE 18 Responsibilities Between Vessels 34

 Section III—Conduct of Vessels in Restricted Visibility 36

 RULE 19 Conduct of Vessels in Restricted Visibility 36

PART C—LIGHTS AND SHAPES 38

 RULE 20 Application..... 38

 RULE 21 Definitions 40

 RULE 22 Visibility of Lights..... 42

 RULE 23 Power-driven Vessels Underway 44

 RULE 24 Towing and Pushing 52

 RULE 25 Sailing Vessels Underway and Vessels Under Oars 72

 RULE 26 Fishing Vessels 80

 RULE 27 Vessels Not Under Command or Restricted in Their Ability to Maneuver 88

RULE 28 Vessels Constrained by Their Draft	102
RULE 29 Pilot Vessels	104
RULE 30 Anchored Vessels and Vessels Aground	106
RULE 31 Seaplanes	112
PART D—SOUND AND LIGHT SIGNALS	114
RULE 32 Definitions	114
RULE 33 Equipment for Sound Signals	114
RULE 34 Maneuvering and Warning Signals	116
RULE 35 Sound Signals in Restricted Visibility	120
RULE 36 Signals to Attract Attention	124
RULE 37 Distress Signals	126
PART E—EXEMPTIONS	128
RULE 38 Exemptions	128
ANNEX I - Positioning and Technical Details of Lights and Shapes	132
ANNEX II - Additional Signals for Fishing Vessels Fishing in Close Proximity	150
ANNEX III - Technical Details of Sound Signal Appliances	152
ANNEX IV - Distress Signals	162
ANNEX V (33 CFR 88) - Pilot Rules	167
INTERPRETATIVE RULES	174
COLREGS DEMARCATION LINES	176
PENALTY PROVISIONS	199
Violations of International Navigation Rules and Regulations	199
Violations of Inland Navigation Rules and Regulations	199
Penalties for Negligent Operations	200
Duties Related to Marine Casualty Assistance and Information	200
Duty to Provide Assistance at Sea	200
Injunctions	200
ALTERNATIVE COMPLIANCE	204
WATERS SPECIFIED BY THE SECRETARY	207
VESSEL BRIDGE-TO-BRIDGE RADIOTELEPHONE REGULATIONS ..	208

INTRODUCTION

International Rules

The International Rules in this book were formalized in the Convention on the International Regulations for Preventing Collisions at Sea, 1972, and became effective on July 15, 1977. The Rules (commonly called 72 COLREGS) are part of the Convention, and vessels flying the flags of states ratifying the treaty are bound to the Rules. The United States has ratified this treaty and all United States flag vessels must adhere to these Rules where applicable. President Gerald R. Ford proclaimed 72 COLREGS and the Congress adopted them as the International Navigational Rules Act of 1977.

The 72 COLREGS were developed by the Inter-Governmental Maritime Consultative Organization (IMCO) which in May 1982 was renamed the International Maritime Organization (IMO). In November 1981, IMO's Assembly adopted 55 amendments to the 72 COLREGS which became effective on June 1, 1983. The IMO also adopted 9 more amendments which became effective on November 19, 1989. The International Rules in this book contain these amendments.

These Rules are applicable on waters outside of established navigational lines of demarcation. The lines are called COLREGS Demarcation Lines and delineate those waters upon which mariners shall comply with the Inland and International Rules. COLREGS Demarcation Lines are contained in this book.

CONVERSION TABLE

Conversion of Metric to U.S. Customary/Imperial Units

<i>Metric Measure</i>	<i>U.S. Customary/ Imperial Measure (approx.)</i>
1000 Meters (M)	3280.8 ft.
500 M	1640.4 ft.
200 M	656.2 ft.
150 M	492.1 ft.
100 M	328.1 ft.
75 M	246.1 ft.
60 M	196.8 ft.
50 M	164.0 ft.
25 M	82.0 ft.
20 M	65.6 ft.
12 M	39.4 ft.
10 M	32.8 ft.
8 M	26.2 ft.
7 M	23.0 ft.
6 M	19.7 ft.
5 M	16.4 ft.
4.5 M	14.8 ft.
4.0 M	13.1 ft.
3.5 M	11.5 ft.
2.5 M	8.2 ft.
2.0 M	6.6 ft.
1.5 M	4.9 ft.
1 M	3.3 ft.
.9 M	35.4 in.
.6 M	23.6 in.
.5 M	19.7 in.
300 Millimeters (mm)	11.8 in.
200 mm	7.9 in.

—INTERNATIONAL— General

PART A—GENERAL

RULE 1 Application

- (a) These Rules shall apply to all vessels upon the high seas and in all waters connected therewith navigable by seagoing vessels.
- (b) Nothing in these Rules shall interfere with the operation of special rules made by an appropriate authority for roadsteads, harbors, rivers, lakes or inland waterways connected with the high seas and navigable by seagoing vessels. Such special rules shall conform as closely as possible to these Rules.
- (c) Nothing in these Rules shall interfere with the operation of any special rules made by the Government of any State with respect to additional station or signal lights, shapes or whistle signals for ships of war and vessels proceeding under convoy, with respect to additional station or signal lights or shapes for fishing vessels engaged in fishing as a fleet. These additional station or signal lights, shapes or whistle signals shall, so far as possible, be such that they cannot be mistaken for any light, shape or signal authorized elsewhere under these Rules¹.

¹ Submarines may display, as a distinctive means of identification, an intermittent flashing amber (yellow) beacon with a sequence of one flash per second for three (3) seconds followed by a three (3) second off-period. Other special rules made by the Secretary of the Navy with respect to additional station and signal lights are found in Part 706 of Title 32, Code of Federal Regulations (32 CFR 706).

—INTERNATIONAL—

General

RULE 1—CONTINUED

- (d) Traffic separation schemes may be adopted by the Organization for the purpose of these Rules.
- (e) Whenever the Government concerned shall have determined that a vessel of special construction or purpose cannot comply fully with the provisions of any of these Rules with respect to the number, position, range or arc of visibility of lights or shapes, as well as to the disposition and characteristics of sound-signaling appliances, such vessel shall comply with such other provisions in regard to the number, position, range or arc of visibility of lights or shapes, as well as to the disposition and characteristics of sound-signaling appliances, as her Government shall have determined to be the closest possible compliance with these Rules in respect to that vessel.

—INTERNATIONAL—

General

RULE 2 Responsibility

- (a) Nothing in these Rules shall exonerate any vessel, or the owner, master or crew thereof, from the consequences of any neglect to comply with these Rules or of the neglect of any precaution which may be required by the ordinary practice of seamen, or by the special circumstances of the case.
- (b) In construing and complying with these Rules due regard shall be had to all dangers of navigation and collision and to any special circumstances, including the limitations of the vessels involved, which may make a departure from these Rules necessary to avoid immediate danger.

RULE 3

General Definitions

For the purpose of these Rules, except where the context otherwise requires:

- (a) The word “vessel” includes every description of water craft, including nondisplacement craft, WIG craft and seaplanes, used or capable of being used as a means of transportation on water.
- (b) The term “power-driven vessel” means any vessel propelled by machinery.
- (c) The term “sailing vessel” means any vessel under sail provided that propelling machinery, if fitted, is not being used.
- (d) The term “vessel engaged in fishing” means any vessel fishing with nets, lines, trawls or other fishing apparatus which restrict maneuverability, but does not include a vessel fishing with trolling lines or other fishing apparatus which do not restrict maneuverability.
- (e) The word “seaplane” includes any aircraft designed to maneuver on the water.
- (f) The term “vessel not under command” means a vessel which through some exceptional circumstance is unable to maneuver as required by these Rules and is therefore unable to keep out of the way of another vessel.
- (g) The term “vessel restricted in her ability to maneuver” means a vessel which from the nature of her work is restricted in her ability to maneuver as required by these Rules and is therefore unable to keep out of the way of another vessel.

—INTERNATIONAL—
General

RULE 3—CONTINUED

- (g) (continued) The term “vessels restricted in their ability to maneuver” shall include but not be limited to:
- (i) a vessel engaged in laying, servicing or picking up a navigation mark, submarine cable or pipeline;
 - (ii) a vessel engaged in dredging, surveying or underwater operations;
 - (iii) a vessel engaged in replenishment or transferring persons, provisions or cargo while underway;
 - (iv) a vessel engaged in the launching or recovery of aircraft;
 - (v) a vessel engaged in mineclearance operations;
 - (vi) a vessel engaged in a towing operation such as severely restricts the towing vessel and her tow in their ability to deviate from their course.
- (h) The term “vessel constrained by her draft” means a power-driven vessel which, because of her draft in relation to the available depth and width of navigable water is severely restricted in her ability to deviate from the course she is following.
- (i) The word “underway” means that a vessel is not at anchor, or made fast to the shore, or aground.
- (j) The words “length” and “breadth” of a vessel means her length overall and greatest breadth.
- (k) Vessels shall be deemed to be in sight of one another only when one can be observed visually from the other.
- (l) The term “restricted visibility” means any condition in which visibility is restricted by fog, mist, falling snow, heavy rainstorms, sandstorms or any other similar causes.
- (m) The term “Wing-In-Ground (WIG) craft” means a multimodal craft which, in its main operational mode, flies in close proximity to the surface by utilizing surface-effect action.

—INTERNATIONAL—
Steering and Sailing Rules

PART B—STEERING AND SAILING RULES

**Section I—Conduct of Vessels in Any
Condition of Visibility**

**RULE 4
Application**

Rules in this Section apply to any condition of visibility.

**RULE 5
Look-out**

Every vessel shall at all times maintain a proper look-out by sight and hearing as well as by all available means appropriate in the prevailing circumstances and conditions so as to make a full appraisal of the situation and of the risk of collision.

—INTERNATIONAL—

Steering and Sailing Rules

RULE 6 **Safe Speed**

Every vessel shall at all times proceed at a safe speed so that she can take proper and effective action to avoid collision and be stopped within a distance appropriate to the prevailing circumstances and conditions.

In determining a safe speed the following factors shall be among those taken into account:

- (a) By all vessels:
 - (i) the state of visibility;
 - (ii) the traffic density including concentrations of fishing vessels or any other vessels;
 - (iii) the maneuverability of the vessel with special reference to stopping distance and turning ability in the prevailing conditions;
 - (iv) at night, the presence of background light such as from shore lights or from back scatter of her own lights;
 - (v) the state of wind, sea and current, and the proximity of navigational hazards;
 - (vi) the draft in relation to the available depth of water.
- (b) Additionally, by vessels with operational radar:
 - (i) the characteristics, efficiency and limitations of the radar equipment;
 - (ii) any constraints imposed by the radar range scale in use;
 - (iii) the effect on radar detection of the sea state, weather and other sources of interference;
 - (iv) the possibility that small vessels, ice and other floating objects may not be detected by radar at an adequate range;
 - (v) the number, location and movement of vessels detected by radar;
 - (vi) the more exact assessment of the visibility that may be possible when radar is used to determine the range of vessels or other objects in the vicinity.

—INTERNATIONAL—

Steering and Sailing Rules

RULE 7 **Risk of Collision**

(a) Every vessel shall use all available means appropriate to the prevailing circumstances and conditions to determine if risk of collision exists. If there is any doubt such risk shall be deemed to exist.

(b) Proper use shall be made of radar equipment if fitted and operational, including long-range scanning to obtain early warning of risk of collision and radar plotting or equivalent systematic observation of detected objects.

(c) Assumptions shall not be made on the basis of scanty information, especially scanty radar information.

(d) In determining if risk of collision exists the following considerations shall be among those taken into account:

- (i) such risk shall be deemed to exist if the compass bearing of an approaching vessel does not appreciably change;
- (ii) such risk may sometimes exist even when an appreciable bearing change is evident, particularly when approaching a very large vessel or a tow or when approaching a vessel at close range.

—INTERNATIONAL—

Steering and Sailing Rules

RULE 8

Action to Avoid Collision

- (a) Any action taken to avoid collision shall be taken in accordance with the Rules of this Part and shall, if the circumstances of the case admit, be positive, made in ample time and with due regard to the observance of good seamanship.
- (b) Any alteration of course and/or speed to avoid collision shall, if the circumstances of the case admit, be large enough to be readily apparent to another vessel observing visually or by radar; a succession of small alterations of course and/or speed should be avoided.
- (c) If there is sufficient sea room, alteration of course alone may be the most effective action to avoid a close-quarters situation provided that it is made in good time, is substantial and does not result in another close-quarters situation.
- (d) Action taken to avoid collision with another vessel shall be such as to result in passing at a safe distance. The effectiveness of the action shall be carefully checked until the other vessel is finally past and clear.
- (e) If necessary to avoid collision or allow more time to assess the situation, a vessel shall slacken her speed or take all way off by stopping or reversing her means of propulsion.
- (f)
 - (i) A vessel which, by any of these rules, is required not to impede the passage or safe passage of another vessel shall, when required by the circumstances of the case, take early action to allow sufficient sea room for the safe passage of the other vessel.
 - (ii) A vessel required not to impede the passage or safe passage of another vessel is not relieved of this obligation if approaching the other vessel so as to involve risk of collision and shall, when taking action, have full regard to the action which may be required by the rules of this part.
 - (iii) A vessel, the passage of which is not to be impeded remains fully obliged to comply with the rules of this part when the two vessels are approaching one another so as to involve risk of collision.

—INTERNATIONAL—

Steering and Sailing Rules

RULE 9

Narrow Channels

- (a) A vessel proceeding along the course of a narrow channel or fairway shall keep as near to the outer limit of the channel or fairway which lies on her starboard side as is safe and practicable.
- (b) A vessel of less than 20 meters in length or a sailing vessel shall not impede the passage of a vessel which can safely navigate only within a narrow channel or fairway.
- (c) A vessel engaged in fishing shall not impede the passage of any other vessel navigating within a narrow channel or fairway.
- (d) A vessel shall not cross a narrow channel or fairway if such crossing impedes the passage of a vessel which can safely navigate only within such channel or fairway. The latter vessel may use the sound signal prescribed in Rule 34(d) if in doubt as to the intention of the crossing vessel.
- (e)
 - (i) In a narrow channel or fairway when overtaking can take place only if the vessel to be overtaken has to take action to permit safe passing, the vessel intending to overtake shall indicate her intention by sounding the appropriate signal prescribed in Rule 34(c)(i). The vessel to be overtaken shall, if in agreement, sound the appropriate signal prescribed in Rule 34(c)(ii) and take steps to permit safe passing. If in doubt she may sound the signals prescribed in Rule 34(d).
 - (ii) This Rule does not relieve the overtaking vessel of her obligation under Rule 13.
- (f) A vessel nearing a bend or an area of a narrow channel or fairway where other vessels may be obscured by an intervening obstruction shall navigate with particular alertness and caution and shall sound the appropriate signal prescribed in Rule 34(e).
- (g) Any vessel shall, if the circumstances of the case admit, avoid anchoring in a narrow channel.

—INTERNATIONAL—

Steering and Sailing Rules

RULE 10

Traffic Separation Schemes

- (a) This Rule applies to traffic separation schemes adopted by the Organization and does not relieve any vessel of her obligation under any other rule.
- (b) A vessel using a traffic separation scheme shall:
- (i) proceed in the appropriate traffic lane in the general direction of traffic flow for that lane;
 - (ii) so far as practicable keep clear of a traffic separation line or separation zone;
 - (iii) normally join or leave a traffic lane at the termination of the lane, but when joining or leaving from either side shall do so at as small an angle to the general direction of traffic flow as practicable.
- (c) A vessel shall, so far as practicable, avoid crossing traffic lanes but if obliged to do so shall cross on a heading as nearly as practicable at right angles to the general direction of traffic flow.
- (d)
- (i) A vessel shall not use an inshore traffic zone when she can safely use the appropriate traffic lane within the adjacent traffic separation scheme. However, vessels of less than 20 meters in length, sailing vessels and vessels engaged in fishing may use the inshore traffic zone.
 - (ii) Notwithstanding subparagraph (d)(i), a vessel may use an inshore traffic zone when en route to or from a port, offshore installation or structure, pilot station or any other place situated within the inshore traffic zone, or to avoid immediate danger.
- (e) A vessel other than a crossing vessel or a vessel joining or leaving a lane shall not normally enter a separation zone or cross a separation line except:
- (i) in cases of emergency to avoid immediate danger;
 - (ii) to engage in fishing within a separation zone.
- (f) A vessel navigating in areas near the terminations of traffic separation schemes shall do so with particular caution.
- (g) A vessel shall so far as practicable avoid anchoring in a traffic separation scheme or in areas near its terminations.
- (h) A vessel not using a traffic separation scheme shall avoid it by as wide a margin as is practicable.
- (i) A vessel engaged in fishing shall not impede the passage of any vessel following a traffic lane.
- (j) A vessel of less than 20 meters in length or a sailing vessel shall not impede the safe passage of a power-driven vessel following a traffic lane.

—INTERNATIONAL—

Steering and Sailing Rules

RULE 10—CONTINUED

- (k) A vessel restricted in her ability to maneuver when engaged in an operation for the maintenance of safety of navigation in a traffic separation scheme is exempted from complying with this Rule to the extent necessary to carry out the operation.
- (l) A vessel restricted in her ability to maneuver when engaged in an operation for the laying, servicing or picking up of a submarine cable, within a traffic separation scheme, is exempted from complying with this Rule to the extent necessary to carry out the operation.

—INTERNATIONAL—
Steering and Sailing Rules

**Section II—Conduct of Vessels in Sight of
One Another**

RULE 11

Application

Rules in this section apply to vessels in sight of one another.

RULE 12

Sailing Vessels

(a) When two sailing vessels are approaching one another, so as to involve risk of collision, one of them shall keep out of the way of the other as follows:

- (i) when each has the wind on a different side, the vessel which has the wind on the port side shall keep out of the way of the other;
- (ii) when both have the wind on the same side, the vessel which is to windward shall keep out of the way of the vessel which is to leeward;
- (iii) if a vessel with the wind on the port side sees a vessel to windward and cannot determine with certainty whether the other vessel has the wind on the port or on the starboard side, she shall keep out of the way of the other.

(b) For the purposes of this Rule the windward side shall be deemed to be the side opposite to that on which the mainsail is carried or, in the case of a square-rigged vessel, the side opposite to that on which the largest fore-and-aft sail is carried.

—INTERNATIONAL—
Steering and Sailing Rules

RULE 13

Overtaking

(a) Notwithstanding anything contained in the Rules of Part B, Sections I and II, any vessel overtaking any other shall keep out of the way of the vessel being overtaken.

(b) A vessel shall be deemed to be overtaking when coming up with another vessel from a direction more than 22.5 degrees abaft her beam, that is, in such a position with reference to the vessel she is overtaking, that at night she would be able to see only the sternlight of that vessel but neither of her sidelights.

(c) When a vessel is in any doubt as to whether she is overtaking another, she shall assume that this is the case and act accordingly. (d) Any subsequent alteration of the bearing between the two vessels shall not make the overtaking vessel a crossing vessel within the meaning of these Rules or relieve her of the duty of keeping clear of the overtaken vessel until she is finally past and clear.

—INTERNATIONAL—

Steering and Sailing Rules

RULE 14 **Head-on Situation**

- (a) When two power-driven vessels are meeting on reciprocal or nearly reciprocal courses so as to involve risk of collision each shall alter her course to starboard so that each shall pass on the port side of the other.
- (b) Such a situation shall be deemed to exist when a vessel sees the other ahead or nearly ahead and by night she could see the masthead lights of the other in a line or nearly in a line and/or both sidelights and by day she observes the corresponding aspect of the other vessel.
- (c) When a vessel is in any doubt as to whether such a situation exists she shall assume that it does exist and act accordingly.

RULE 15 **Crossing Situation**

When two power-driven vessels are crossing so as to involve risk of collision, the vessel which has the other on her own starboard side shall keep out of the way and shall, if the circumstances of the case admit, avoid crossing ahead of the other vessel.

—INTERNATIONAL—

Steering and Sailing Rules

RULE 16 **Action by Give-way Vessel**

Every vessel which is directed to keep out of the way of another vessel shall, so far as possible, take early and substantial action to keep well clear.

RULE 17 **Action by Stand-on Vessel**

- (a)
 - (i) Where one of two vessels is to keep out of the way the other shall keep her course and speed.
 - (ii) The latter vessel may however take action to avoid collision by her maneuver alone, as soon as it becomes apparent to her that the vessel required to keep out of the way is not taking appropriate action in compliance with these Rules.
- (b) When, from any cause, the vessel required to keep her course and speed finds herself so close that collision cannot be avoided by the action of the give-way vessel alone, she shall take such action as will best aid to avoid collision.
- (c) A power-driven vessel which takes action in a crossing situation in accordance with subparagraph (a)(ii) of this Rule to avoid collision with another power-driven vessel shall, if the circumstances of the case admit, not alter course to port for a vessel on her own port side.
- (d) This Rule does not relieve the give-way vessel of her obligation to keep out of the way.

RULE 18

Responsibilities Between Vessels

Except where Rules 9, 10 and 13 otherwise require:

- (a) A power-driven vessel underway shall keep out of the way of:
 - (i) a vessel not under command;
 - (ii) a vessel restricted in her ability to maneuver;
 - (iii) a vessel engaged in fishing;
 - (iv) a sailing vessel.
- (b) A sailing vessel underway shall keep out of the way of:
 - (i) a vessel not under command;
 - (ii) a vessel restricted in her ability to maneuver;
 - (iii) a vessel engaged in fishing.
- (c) A vessel engaged in fishing when underway shall, so far as possible, keep out of the way of:
 - (i) a vessel not under command;
 - (ii) a vessel restricted in her ability to maneuver.
- (d)
 - (i) Any vessel other than a vessel not under command or a vessel restricted in her ability to maneuver shall, if the circumstances of the case admit, avoid impeding the safe passage of a vessel constrained by her draft, exhibiting the signals in Rule 28.
 - (ii) A vessel constrained by her draft shall navigate with particular caution having full regard to her special condition.
- (e) A seaplane on the water shall, in general, keep well clear of all vessels and avoid impeding their navigation. In circumstances, however, where risk of collision exists, she shall comply with the Rules of this Part.
- (f)
 - (i) A WIG craft shall, when taking off, landing and in flight near the surface, keep well clear of all other vessels and avoid impeding their navigation;
 - (ii) A WIG craft operating on the water surface shall comply with the Rules of this Part as a power-driven vessel.

Section III—Conduct of Vessels in Restricted Visibility

RULE 19

Conduct of Vessels in Restricted Visibility

- (a) This Rule applies to vessels not in sight of one another when navigating in or near an area of restricted visibility.
- (b) Every vessel shall proceed at a safe speed adapted to the prevailing circumstances and conditions of restricted visibility. A power-driven vessel shall have her engines ready for immediate maneuver.
- (c) Every vessel shall have due regard to the prevailing circumstances and conditions of restricted visibility when complying with the Rules of Section I of this Part.
- (d) A vessel which detects by radar alone the presence of another vessel shall determine if a close-quarters situation is developing and/or risk of collision exists. If so, she shall take avoiding action in ample time, provided that when such action consists of an alteration of course, so far as possible the following shall be avoided:
 - (i) an alteration of course to port for a vessel forward of the beam, other than for a vessel being overtaken;
 - (ii) an alteration of course towards a vessel abeam or abaft the beam.
- (e) Except where it has been determined that a risk of collision does not exist, every vessel which hears apparently forward of her beam the fog signal of another vessel, or which cannot avoid a close-quarters situation with another vessel forward of her beam, shall reduce her speed to the minimum at which she can be kept on her course. She shall if necessary take all her way off and in any event navigate with extreme caution until danger of collision is over.

—INTERNATIONAL—

Lights and Shapes

PART C—LIGHTS AND SHAPES

RULE 20

Application

- (a) Rules in this Part shall be complied with in all weathers.
- (b) The Rules concerning lights shall be complied with from sunset to sunrise, and during such times no other lights shall be exhibited, except such lights as cannot be mistaken for the lights specified in these Rules or do not impair their visibility or distinctive character, or interfere with the keeping of a proper look-out.
- (c) The lights prescribed by these Rules shall, if carried, also be exhibited from sunrise to sunset in restricted visibility and may be exhibited in all other circumstances when it is deemed necessary.
- (d) The Rules concerning shapes shall be complied with by day.
- (e) The lights and shapes specified in these Rules shall comply with the provisions of Annex I to these Regulations.

—INTERNATIONAL—

Lights and Shapes

RULE 21

Definitions

- (a) "Masthead light" means a white light placed over the fore and aft centerline of the vessel showing an unbroken light over an arc of the horizon of 22.5 degrees and so fixed as to show the light from right ahead to 22.5 degrees abaft the beam on either side of the vessel.
- (b) "Sidelights" means a green light on the starboard side and a red light on the port side each showing an unbroken light over an arc of the horizon of 112.5 degrees and so fixed as to show the light from right ahead to 22.5 degrees abaft the beam on its respective side. In a vessel of less than 20 meters in length the sidelights may be combined in one lantern carried on the fore and aft centerline of the vessel.
- (c) "Sternlight" means a white light placed as nearly as practicable at the stern showing an unbroken light over an arc of the horizon of 135 degrees and so fixed as to show the light 67.5 degrees from right aft on each side of the vessel.
- (d) "Towing light" means a yellow light having the same characteristics as the "sternlight" defined in paragraph (c) of this Rule.
- (e) "All-round light" means a light showing an unbroken light over an arc of the horizon of 360 degrees.
- (f) "Flashing light" means a light flashing at regular intervals at a frequency of 120 flashes or more per minute.

—INTERNATIONAL—

Lights and Shapes

RULE 22

Visibility of Lights

The lights prescribed in these Rules shall have an intensity as specified in Section 8 of Annex I to these Regulations so as to be visible at the following minimum ranges:

- (a) In vessels of 50 meters or more in length:
 - a masthead light, 6 miles;
 - a sidelight, 3 miles;
 - a sternlight, 3 miles;
 - a towing light, 3 miles;
 - a white, red, green or yellow all-round light, 3 miles.
- (b) In vessels of 12 meters or more in length but less than 50 meters in length:
 - a masthead light, 5 miles; except that where the length of the vessel is less than 20 meters, 3 miles;
 - a sidelight, 2 miles;
 - a sternlight, 2 miles;
 - a towing light, 2 miles;
 - a white, red, green or yellow all-round light, 2 miles.
- (c) In vessels of less than 12 meters in length:
 - a masthead light, 2 miles;
 - a sidelight, 1 mile;
 - a sternlight, 2 miles;
 - a towing light, 2 miles;
 - a white, red, green or yellow all-round light, 2 miles.
- (d) In inconspicuous, partly submerged vessels or objects being towed:
 - (a) a white all-round light, 3 miles.

—INTERNATIONAL—

Lights and Shapes

RULE 23

Power-driven Vessels Underway

- (a) A power-driven vessel underway shall exhibit:
 - (i) a masthead light forward;
 - (ii) a second masthead light abaft of and higher than the forward one; except that a vessel of less than 50 meters in length shall not be obliged to exhibit such light but may do so;
 - (iii) sidelights; and
 - (iv) a sternlight.

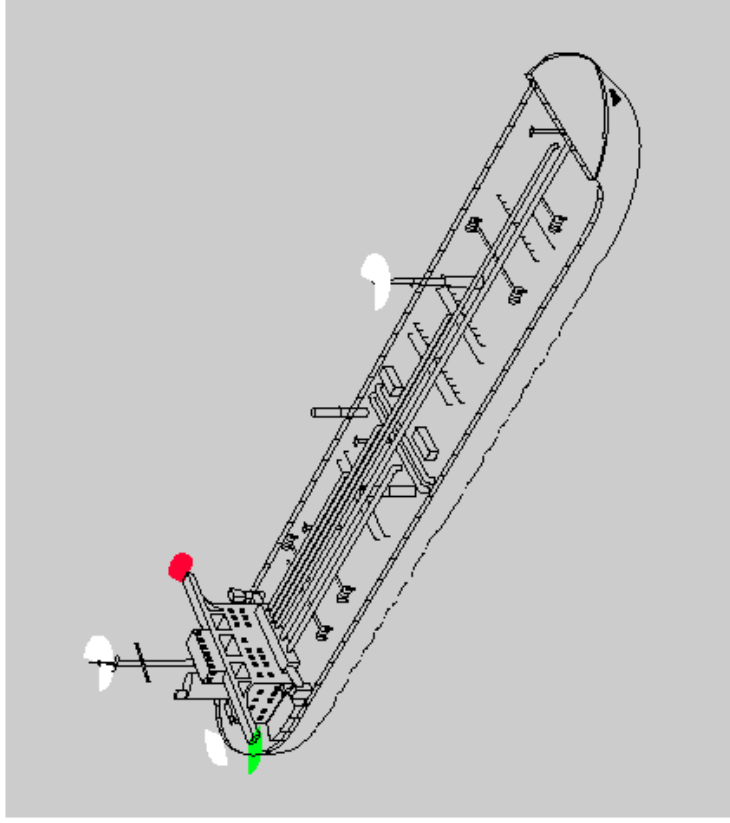

Power-driven vessel underway. Same for Inland.

—INLAND—
Lights and Shapes

RULE 23

Power-driven Vessels Underway

- (a) A power-driven vessel underway shall exhibit:
- (i) a masthead light forward;
 - (ii) a second masthead light abaft of and higher than the forward one; except that a vessel of less than 50 meters in length shall not be obliged to exhibit such light but may do so;
 - (iii) sidelights; and
 - (iv) a sternlight.

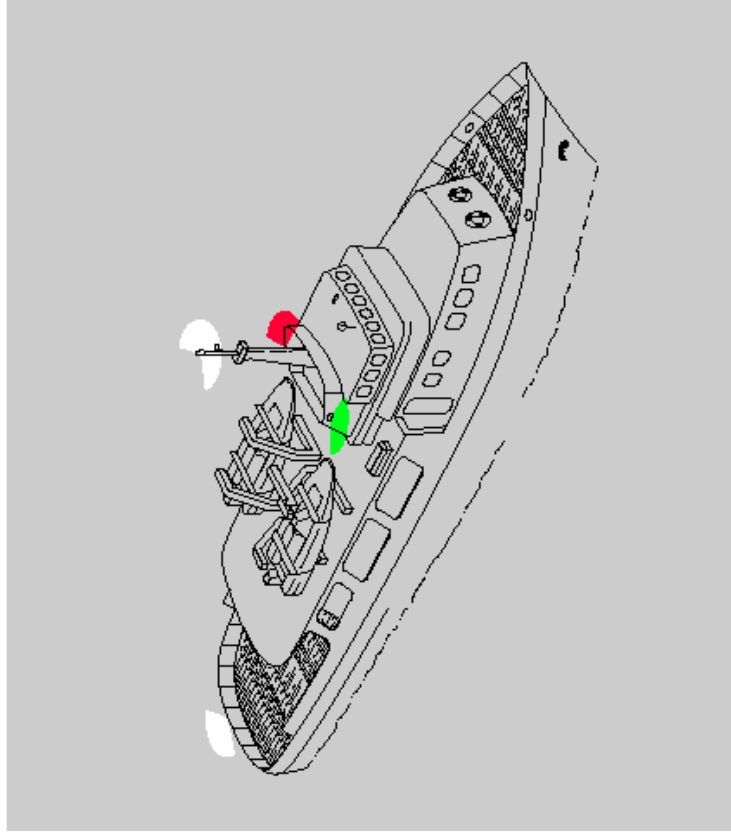

Power-driven vessel underway - less than 50 meters in length.
Same for International.

—INTERNATIONAL—
Lights and Shapes

RULE 23—CONTINUED

- (b) An air-cushion vessel when operating in the nondisplacement mode shall, in addition to the lights prescribed in paragraph (a) of this Rule, exhibit an all-round flashing yellow light.

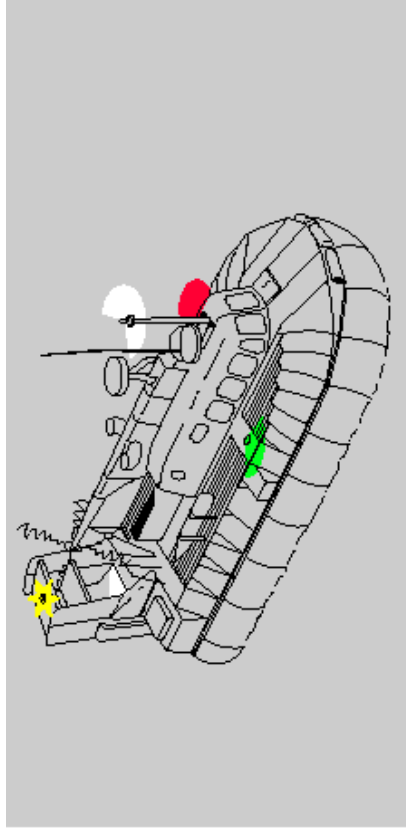

Air-cushion vessel when operating in the nondisplacement mode - vessel less than 50 meters in length.

—INLAND—

Lights and Shapes

RULE 23—CONTINUED

(b) An air-cushion vessel when operating in the nondisplacement mode shall, in addition to the lights prescribed in paragraph (a) of this Rule, exhibit an all-round flashing yellow light where it can best be seen.

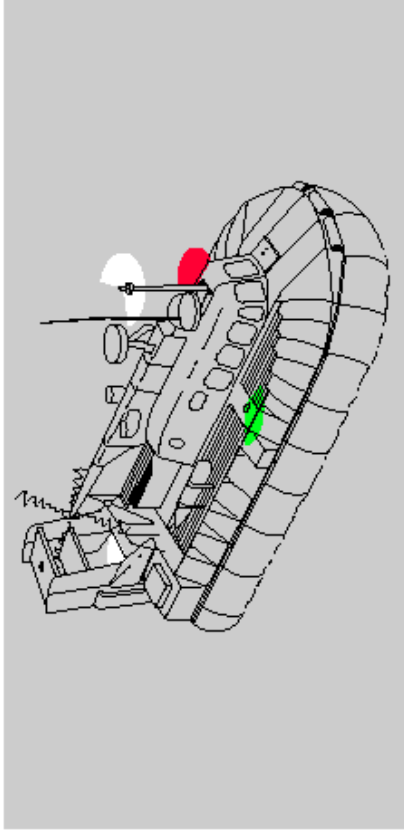

Air-cushion vessel when operating in the displacement mode - vessel less than 50 meters in length.

—INTERNATIONAL—

Lights and Shapes

RULE 23—CONTINUED

(c) A WIG craft only when taking off, landing and in flight near the surface shall, in addition to the lights prescribed in paragraph (a) of this Rule, exhibit a high intensity all-round flashing red light.

- (d)
- (i) A power-driven vessel of less than 12 meters in length may in lieu of the lights prescribed in paragraph (a) of this Rule exhibit an all-round white light and sidelights;
 - (ii) a power-driven vessel of less than 7 meters in length whose maximum speed does not exceed 7 knots may in lieu of the lights prescribed in paragraph (a) of this Rule exhibit an all-round white light and shall, if practicable, also exhibit sidelights;
 - (iii) the masthead light or all-round white light on a power-driven vessel of less than 12 meters in length may be displaced from the fore and aft centerline of the vessel if centerline fitting is not practicable, provided that the sidelights are combined in one lantern which shall be carried on the fore and aft centerline of the vessel or located as nearly as practicable in the same fore and aft line as the masthead light or the all-round white light.

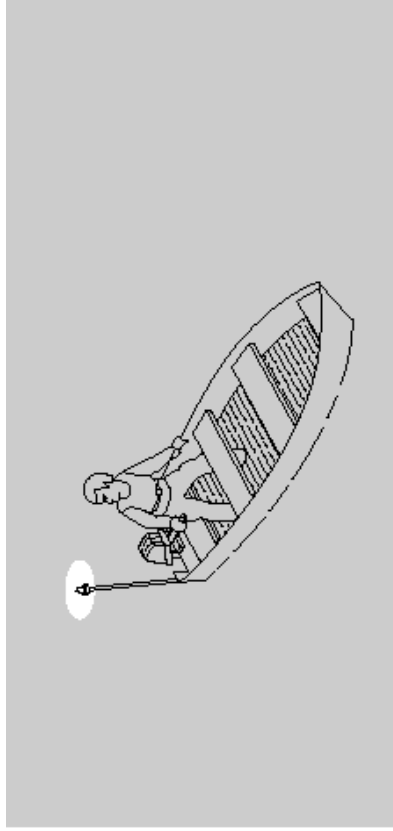

Power-driven vessel of less than 7 meters in length whose maximum speed does not exceed 7 knots.

—INLAND—

Lights and Shapes

RULE 23—CONTINUED

(c) A power-driven vessel of less than 12 meters in length may, in lieu of the lights prescribed in paragraph (a) of this Rule, exhibit an all-round white light and sidelights.

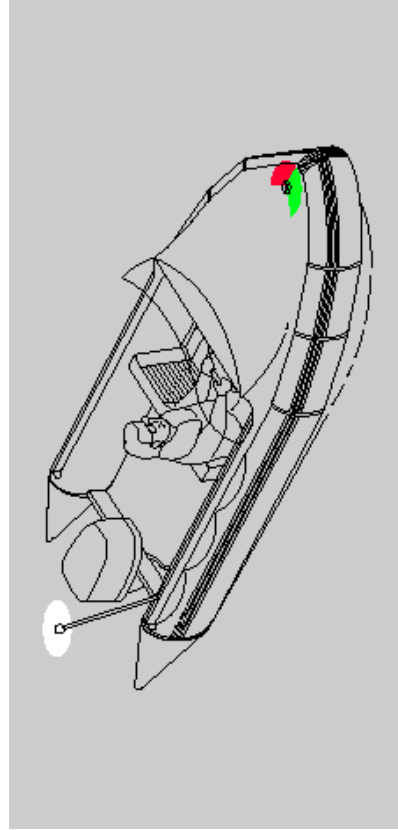

Power-driven vessel of less than 12 meters in length. Same for International.

—INTERNATIONAL—

Lights and Shapes

RULE 24

Towing and Pushing

(a) A power-driven vessel when towing shall exhibit:
(i) instead of the light prescribed in Rule 23(a)(i) or (a)(ii), two masthead lights in a vertical line. When the length of the tow, measuring from the stern of the towing vessel to the after end of the tow exceeds 200 meters, three such lights in a vertical line;
(ii) sidelights;
(iii) a sternlight;
(iv) a towing light in a vertical line above the sternlight; and (v) when the length of the tow exceeds 200 meters, a diamond shape where it can best be seen.

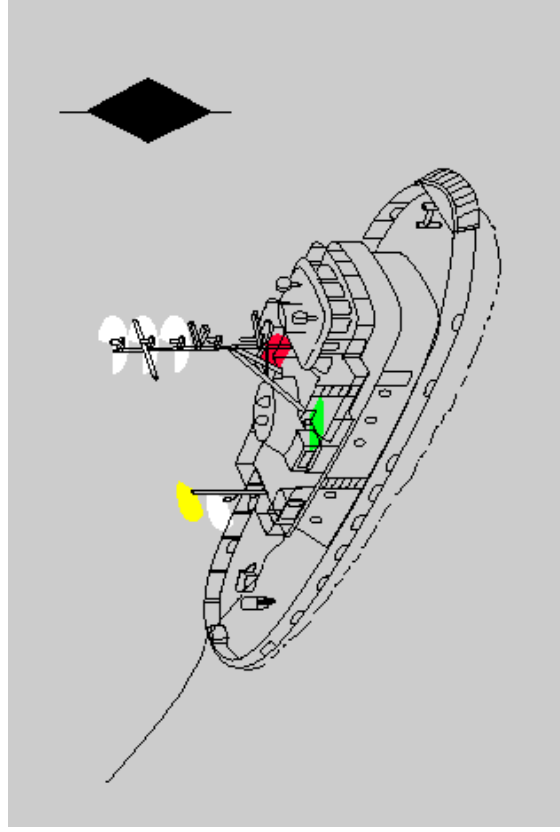

Power-driven vessel towing astern - towing vessel less than 50 meters in length; length of tow exceeds 200 meters. Same for Inland

—INLAND—
Lights and Shapes

RULE 24

Towing and Pushing

- (a) A power-driven vessel when towing astern shall exhibit:
- (i) instead of the light prescribed either in Rule 23(a)(i) or 23(a)(ii), two masthead lights in a vertical line. When the length of the tow, measuring from the stern of the towing vessel to the after end of the tow exceeds 200 meters, three such lights in a vertical line;
 - (ii) sidelights;
 - (iii) a sternlight;
 - (iv) a towing light in a vertical line above the sternlight; and (v) when the length of the tow exceeds 200 meters, a diamond shape where it can best be seen.

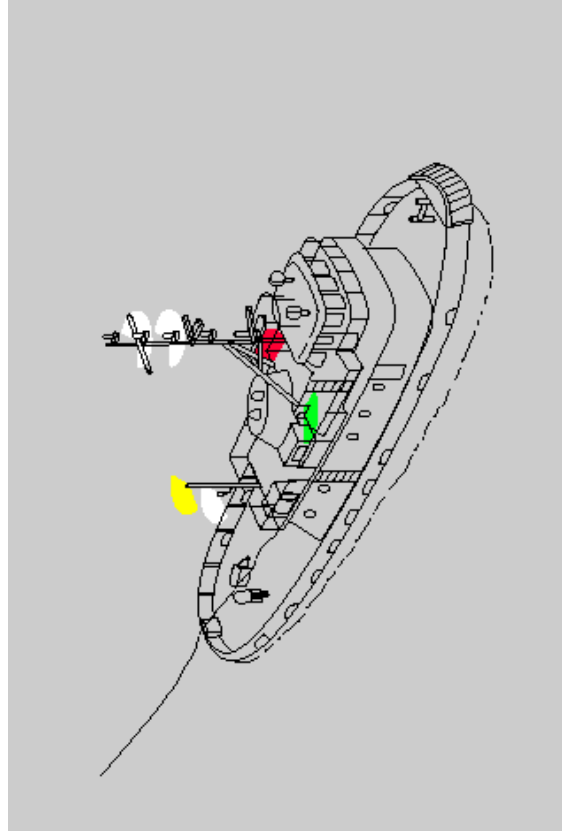

Power-driven vessel towing astern - towing vessel less than 50 meters in length; length of tow 200 meters or less. Same for International.

—INTERNATIONAL—
Lights and Shapes

RULE 24—CONTINUED

- (b) When a pushing vessel and a vessel being pushed ahead are rigidly connected in a composite unit they shall be regarded as a power-driven vessel and exhibit the lights prescribed in Rule 23.

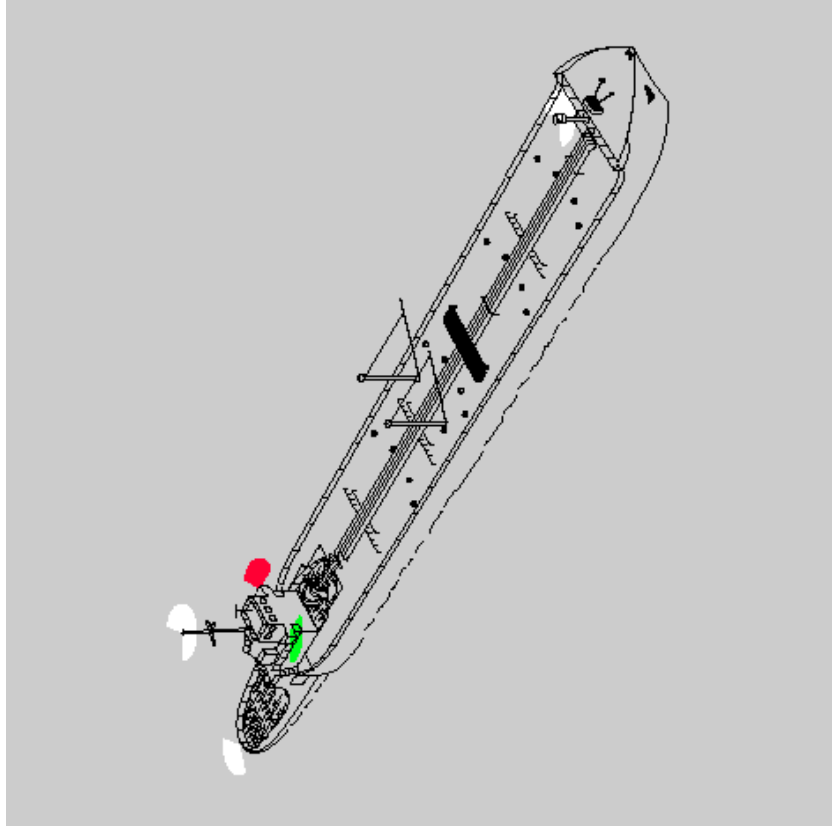

Composite unit underway. Same for Inland.

—INLAND—
Lights and Shapes

RULE 24—CONTINUED

(b) When a pushing vessel and a vessel being pushed ahead are rigidly connected in a composite unit they shall be regarded as a power-driven vessel and exhibit the lights prescribed in Rule 23.

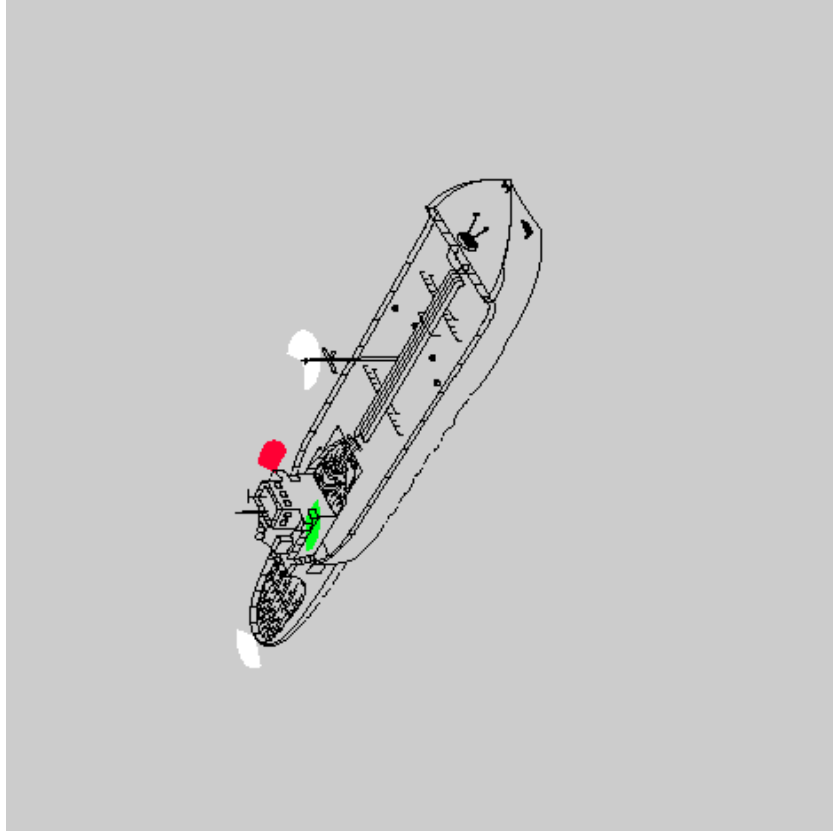

Composite unit underway - less than 50 meters in length.
Same for International.

—INTERNATIONAL—
Lights and Shapes

RULE 24—CONTINUED

(c) A power-driven vessel when pushing ahead or towing alongside, except in the case of a composite unit, shall exhibit:
(i) instead of the light prescribed in Rule 23(a)(i) or 23(a)(ii), two masthead lights in a vertical line;
(ii) sidelights; and
(iii) a sternlight.

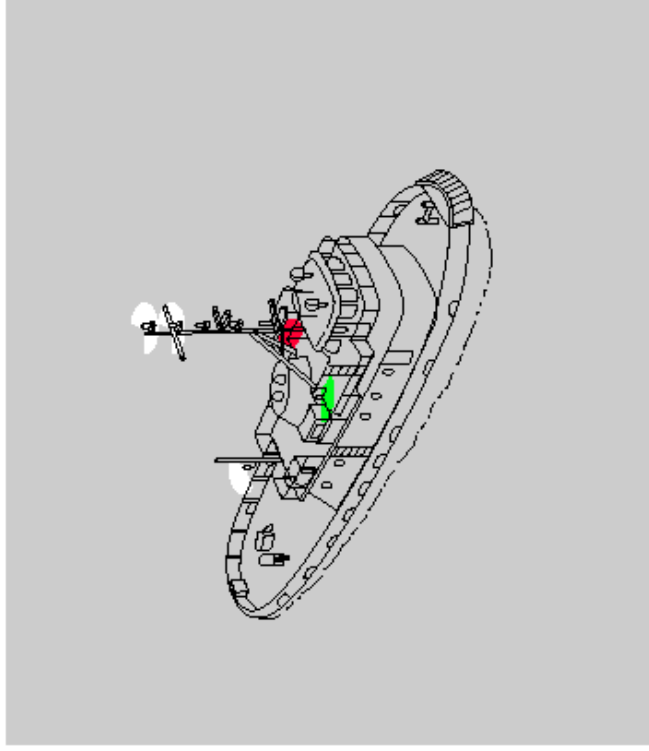

Power-driven vessel pushing ahead or towing alongside—towing vessel less than 50 meters in length.

—INLAND—
Lights and Shapes

RULE 24—CONTINUED

- (c) A power-driven vessel when pushing ahead or towing alongside, except as required by paragraphs (b) and (i) of this Rule, shall exhibit:
- (i) instead of the light prescribed either in Rule 23(a)(i) or 23(a)(ii), two masthead lights in a vertical line;
 - (ii) sidelights; and
 - (iii) two towing lights in a vertical line.

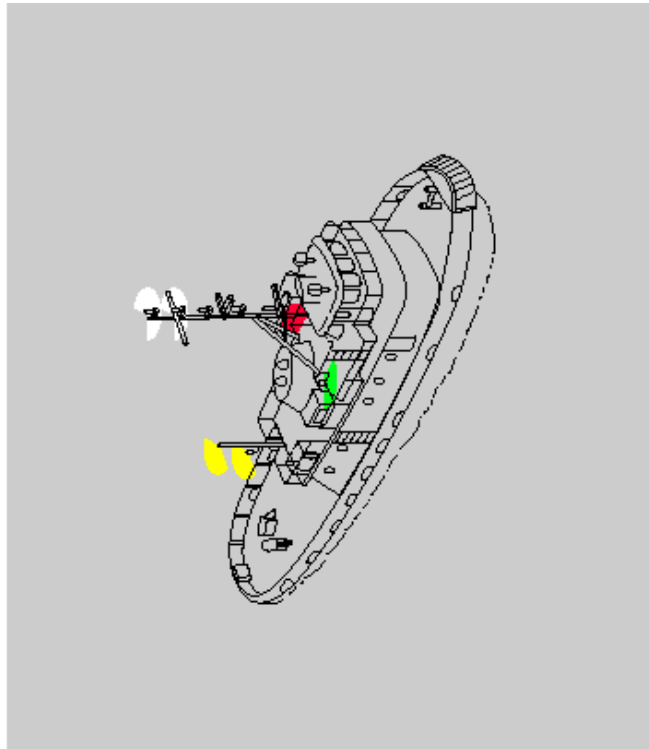

Power-driven vessel pushing ahead or towing alongside—towing vessel less than 50 meters in length.

—INTERNATIONAL—
Lights and Shapes

RULE 24—CONTINUED

- (d) A power-driven vessel to which paragraph (a) or (c) of this Rule apply shall also comply with Rule 23(a)(ii).

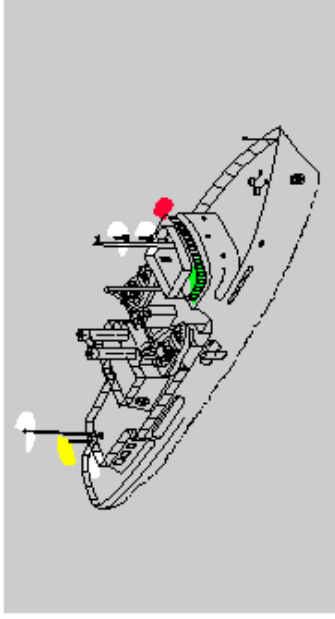

Power-driven vessel towing astern—length of tow 200 meters or less. The after masthead light is optional for vessel less than 50 meters in length. Same for Inland.

- (e) A vessel or object being towed, other than those mentioned in paragraph (g) of this Rule, shall exhibit:
- (i) sidelights;
 - (ii) a sternlight;
 - (iii) when the length of the tow exceeds 200 meters, a diamond shape where it can best be seen.

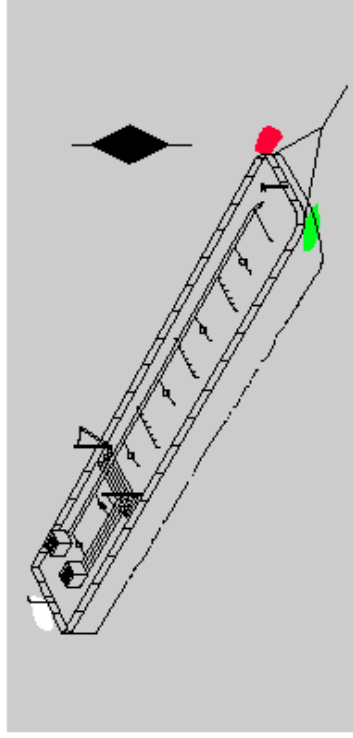

Vessel or object being towed—length of tow exceeds 200 meters. Same for Inland.

—INLAND—
Lights and Shapes

RULE 24—CONTINUED

A power-driven vessel to which paragraphs (a) or (c) of this Rule apply shall also comply with Rule 23(a)(i) and 23(a)(ii).

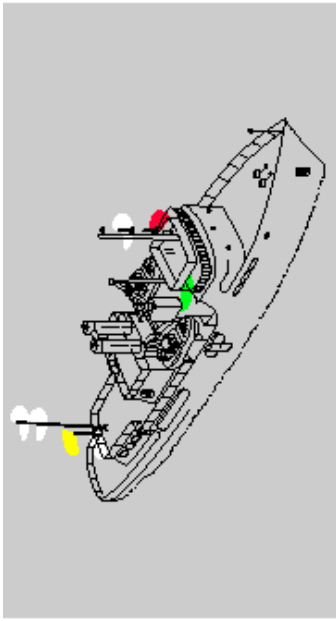

Power-driven vessel towing astern—length of tow 200 meters or less. When masthead lights for towing or pushing are exhibited aft, a forward masthead light is required. Same for International.

- (d) A vessel or object other than those referred to in paragraph (g) of this Rule being towed shall exhibit:
- (i) sidelights;
 - (ii) a sternlight; and
 - (iii) when the length of the tow exceeds 200 meters, a diamond shape where it can best be seen.

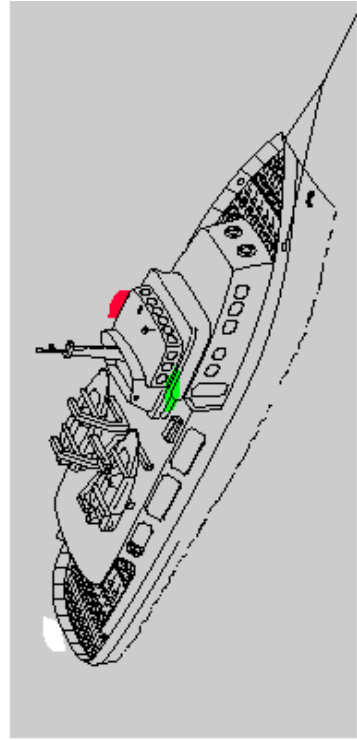

Vessel being towed—length of tow 200 meters or less. Same for International.

—INTERNATIONAL—
Lights and Shapes

RULE 24—CONTINUED

(f) Provided that any number of vessels being towed alongside or pushed in a group shall be lighted as one vessel:

- (i) a vessel being pushed ahead, not being part of a composite unit, shall exhibit at the forward end, sidelights;
- (ii) a vessel being towed alongside shall exhibit a sternlight and at the forward end, sidelights.

—INTERNATIONAL—

Lights and Shapes

RULE 24—CONTINUED

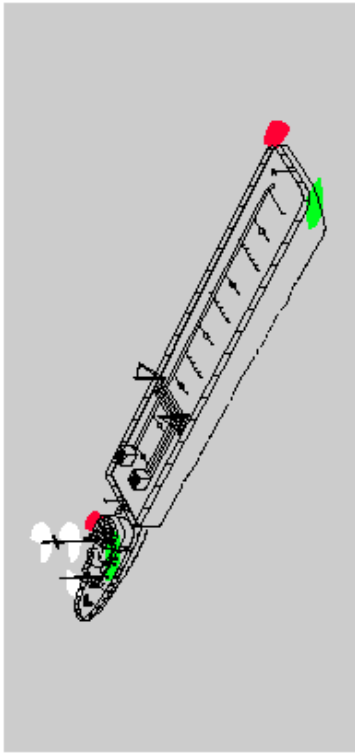

Vessel being pushed ahead, not being part of a composite unit.

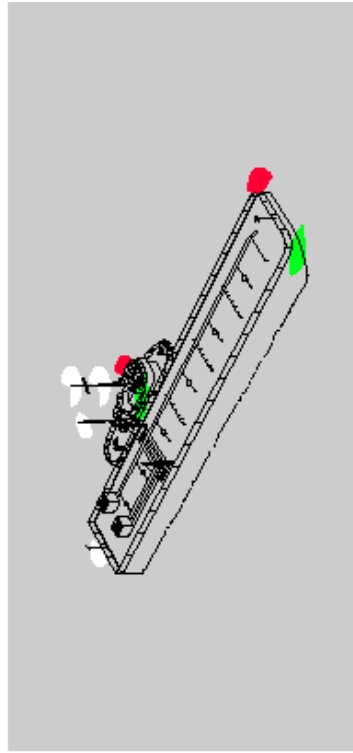

Vessel being towed alongside.

—INTERNATIONAL—

Lights and Shapes

RULE 24—CONTINUED

(g) An inconspicuous, partly submerged vessel or object, or combination of such vessels or objects being towed, shall exhibit:

(h) if it is less than 25 meters in breadth, one all-round white light at or near the forward end and one at or near the after end except that dracones need not exhibit a light at or near the forward end;

(i) if it is 25 meters or more in breadth, two additional all-round white lights at or near the extremities of its breadth;

(ii) if it exceeds 100 meters in length, additional all-round white lights between the lights prescribed in subparagraphs (i) and (ii) so that the distance between the lights shall not exceed 100 meters;

(iii) a diamond shape at or near the aftermost extremity of the last vessel or object being towed and if the length of the tow exceeds 200 meters an additional diamond shape where it can best be seen and located as far forward as is practicable.

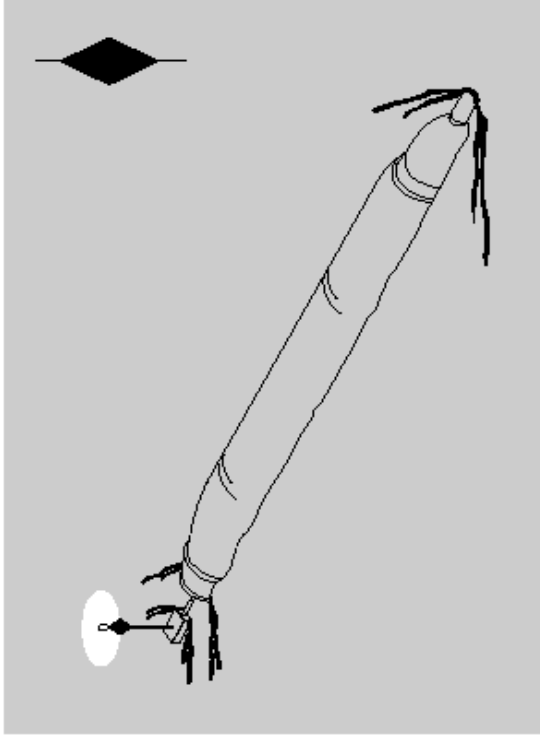

Dracone being towed.

—INTERNATIONAL—
Lights and Shapes

RULE 24—CONTINUED

(h) Where from any sufficient cause it is impracticable for a vessel or object being towed to exhibit the lights or shapes prescribed in paragraph (e) or (g) of this Rule, all possible measures shall be taken to light the vessel or object towed or at least to indicate the presence of such vessel or object.

—INTERNATIONAL—
Lights and Shapes

RULE 24—CONTINUED

(i) Where from any sufficient cause it is impracticable for a vessel not normally engaged in towing operations to display the lights prescribed in paragraph (a) or (c) of this Rule, such vessel shall not be required to exhibit those lights when engaged in towing another vessel in distress or otherwise in need of assistance. All possible measures shall be taken to indicate the nature of the relationship between the towing vessel and the vessel being towed as authorized by Rule 36, in particular by illuminating the towline.

—INTERNATIONAL—
Lights and Shapes

RULE 25
Sailing Vessels Underway and Vessels Under Oars

- (a) A sailing vessel underway shall exhibit:
 - (i) sidelights;
 - (ii) a stern light.
- (b) In a sailing vessel of less than 20 meters in length the lights prescribed in paragraph (a) of this Rule may be combined in one lantern carried at or near the top of the mast where it can best be seen.

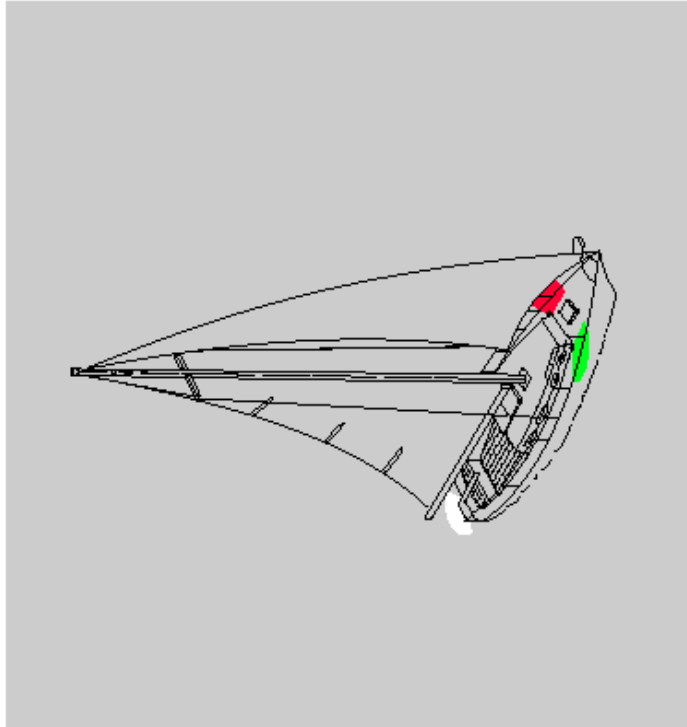

Sailing vessel underway. Same for Inland.

—INLAND—
Lights and Shapes

RULE 25
Sailing Vessels Underway and Vessels Under Oars

- (a) A sailing vessel underway shall exhibit:
 - (i) sidelights; and
 - (ii) a stern light.
- (b) In a sailing vessel of less than 20 meters in length the lights prescribed in paragraph (a) of this Rule may be combined in one lantern carried at or near the top of the mast where it can best be seen.

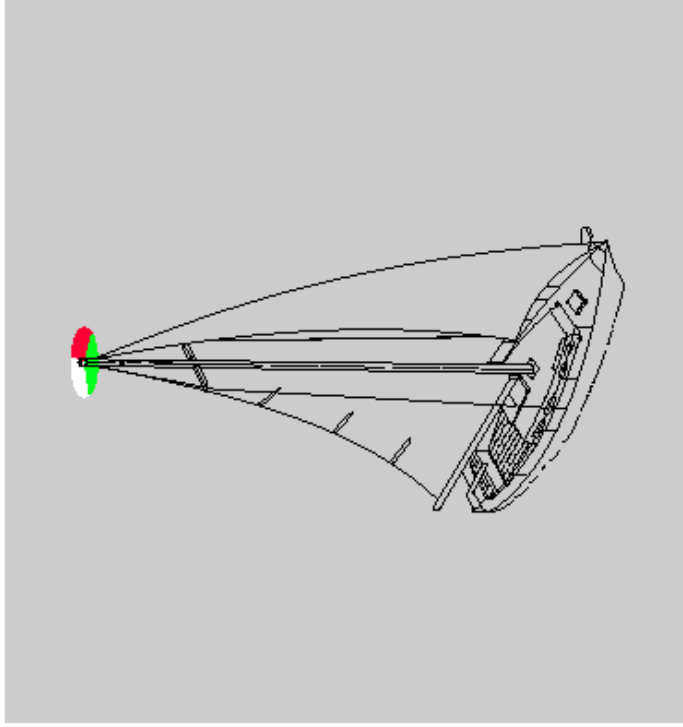

Sailing vessel underway—less than 20 meters in length.
Same for International.

—INTERNATIONAL—
Lights and Shapes

RULE 25—CONTINUED

(c) A sailing vessel underway may, in addition to the lights prescribed in paragraph (a) of this Rule, exhibit at or near the top of the mast, where they can best be seen, two all-round lights in a vertical line, the upper being red and the lower green, but these lights shall not be exhibited in conjunction with the combined lantern permitted by paragraph (b) of this Rule.

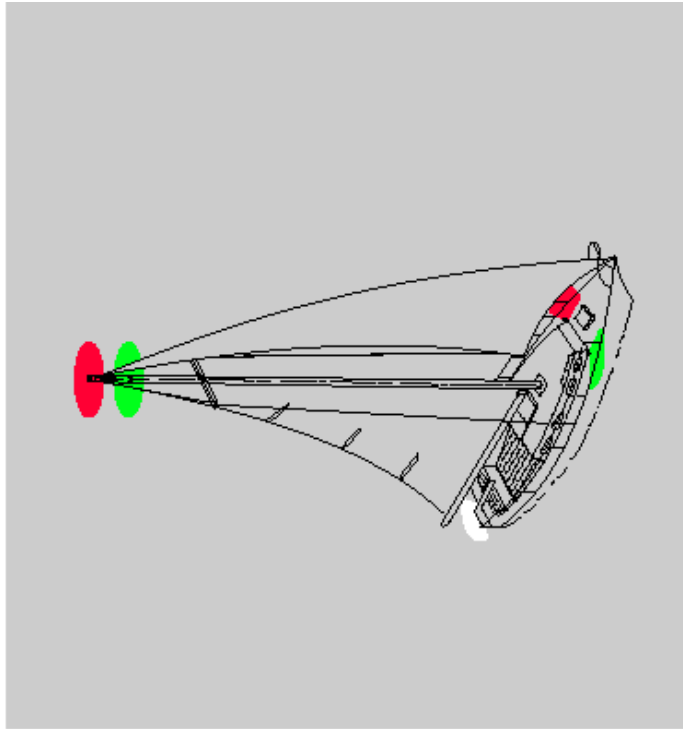

Sailing vessel underway. Same for Inland.

—INTERNATIONAL—
Lights and Shapes

RULE 25—CONTINUED

(d) (i) A sailing vessel of less than 7 meters in length shall, if practicable, exhibit the lights prescribed in paragraph (a) or (b) of this Rule, but if she does not, she shall have ready at hand an electric torch or lighted lantern showing a white light which shall be exhibited in sufficient time to prevent collision.
(ii) A vessel under oars may exhibit the lights prescribed in this Rule for sailing vessels, but if she does not, she shall have ready at hand an electric torch or lighted lantern showing a white light which shall be exhibited in sufficient time to prevent collision.

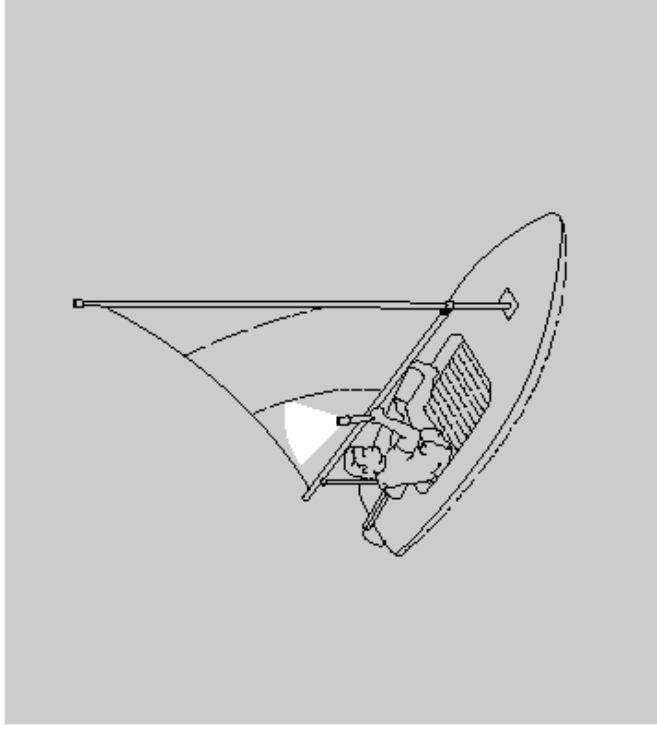

Sailing vessel underway—less than 7 meters in length.
Same for Inland.

—INLAND—
Lights and Shapes

RULE 25—CONTINUED

- (d)
- (i) A sailing vessel of less than 7 meters in length shall, if practicable, exhibit the lights prescribed in paragraph (a) or (b) of this Rule, but if she does not, she shall have ready at hand an electric torch or lighted lantern showing a white light which shall be exhibited in sufficient time to prevent collision.
 - (ii) A vessel under oars may exhibit the lights prescribed in this Rule for sailing vessels, but if she does not, she shall have ready at hand an electric torch or lighted lantern showing a white light which shall be exhibited in sufficient time to prevent collision.

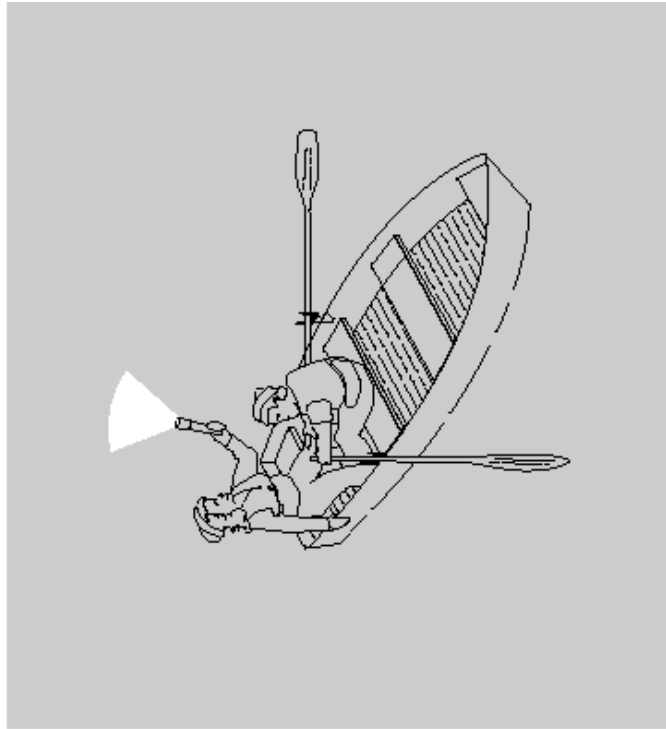

Vessel under oars. Same for International.

—INTERNATIONAL—
Lights and Shapes

RULE 25—CONTINUED

- (e) A vessel proceeding under sail when also being propelled by machinery shall exhibit forward where it can best be seen a conical shape, apex downwards.

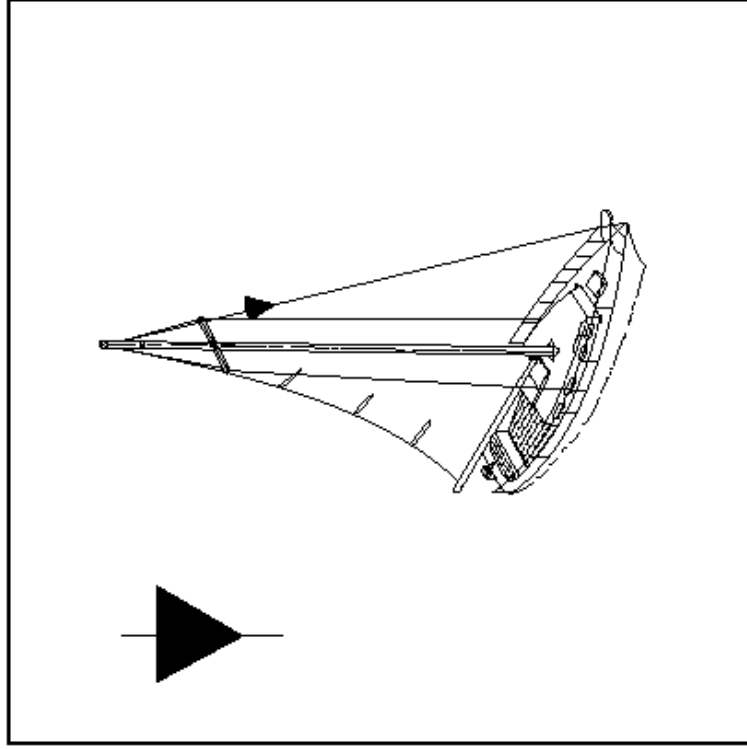

Vessel proceeding under sail when also being propelled by machinery. Same for Inland except that a vessel of less than 12 meters in length is not required to exhibit the dayshape.

—INTERNATIONAL—

Lights and Shapes

RULE 26 Fishing Vessels

- (a) A vessel engaged in fishing, whether underway or at anchor, shall exhibit only the lights and shapes prescribed in this Rule.
- (b) A vessel when engaged in trawling, by which is meant the dragging through the water of a dredge net or other apparatus used as a fishing appliance, shall exhibit:
 - (i) two all-round lights in a vertical line, the upper being green and the lower white, or a shape consisting of two cones with their apexes together in a vertical line one above the other;
 - (ii) a masthead light abaft of and higher than the all-round green light; a vessel of less than 50 meters in length shall not be obliged to exhibit such a light but may do so;
 - (iii) when making way through the water, in addition to the lights prescribed in this paragraph, sidelights and a sternlight.

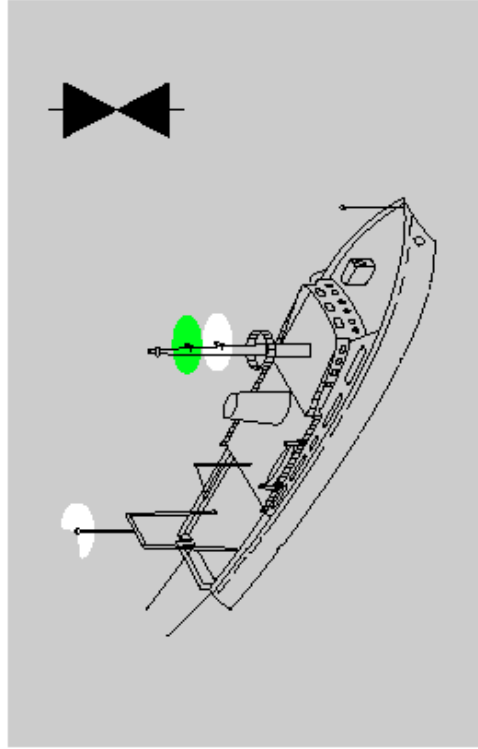

Vessel engaged in trawling—not making way. Same for Inland.

—INLAND—

Lights and Shapes

RULE 26 Fishing Vessels

- (a) A vessel engaged in fishing, whether underway or at anchor, shall exhibit only the lights and shapes prescribed in this Rule.
- (b) A vessel when engaged in trawling, by which is meant the dragging through the water of a dredge net or other apparatus used as a fishing appliance, shall exhibit:
 - (i) two all-round lights in a vertical line, the upper being green and the lower white, or a shape consisting of two cones with their apexes together in a vertical line one above the other;
 - (ii) a masthead light abaft of and higher than the all-round green light; a vessel of less than 50 meters in length shall not be obliged to exhibit such a light but may do so; and
 - (iii) when making way through the water, in addition to the lights prescribed in this paragraph, sidelights and a sternlight.

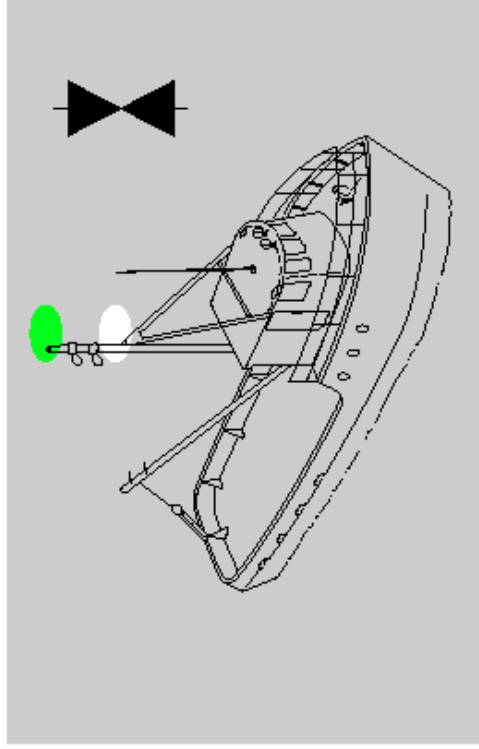

Vessel engaged in trawling—not making way; vessel less than 50 meters in length. Same for International.

—INTERNATIONAL—
Lights and Shapes

RULE 26—CONTINUED

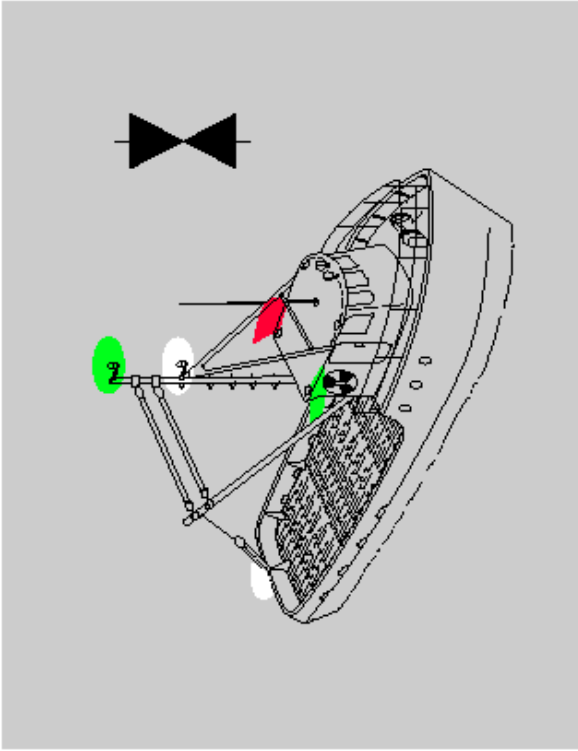

Vessel engaged in trawling—making way; vessel less than 50 meters in length. Same for Inland.

—INLAND—
Lights and Shapes

RULE 26—CONTINUED

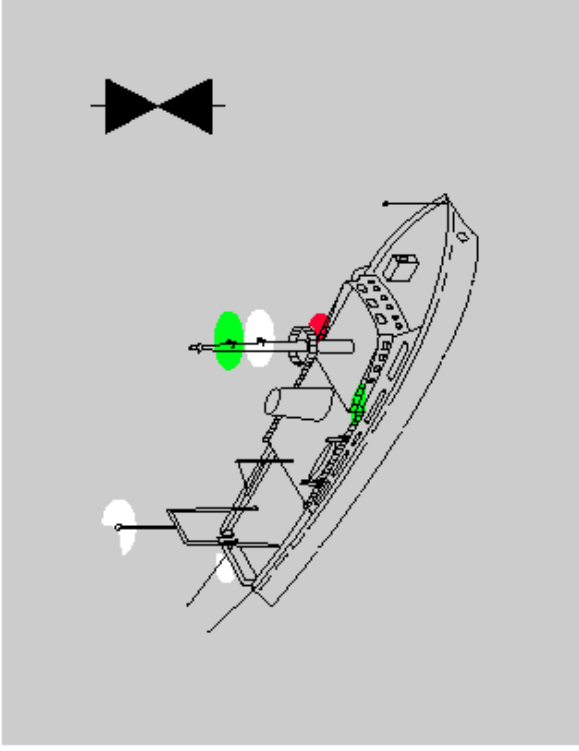

Vessel engaged in trawling—making way. Same for International.

—INTERNATIONAL—

Lights and Shapes

RULE 26—CONTINUED

- (c) A vessel engaged in fishing, other than trawling, shall exhibit:
- (i) two all-round lights in a vertical line, the upper being red and the lower white, or a shape consisting of two cones with apexes together in a vertical line one above the other;
 - (ii) when there is outlying gear extending more than 150 meters horizontally from the vessel, an all-round white light or a cone apex upwards in the direction of the gear;
 - (iii) when making way through the water, in addition to the lights prescribed in this paragraph, sidelights and a sternlight.

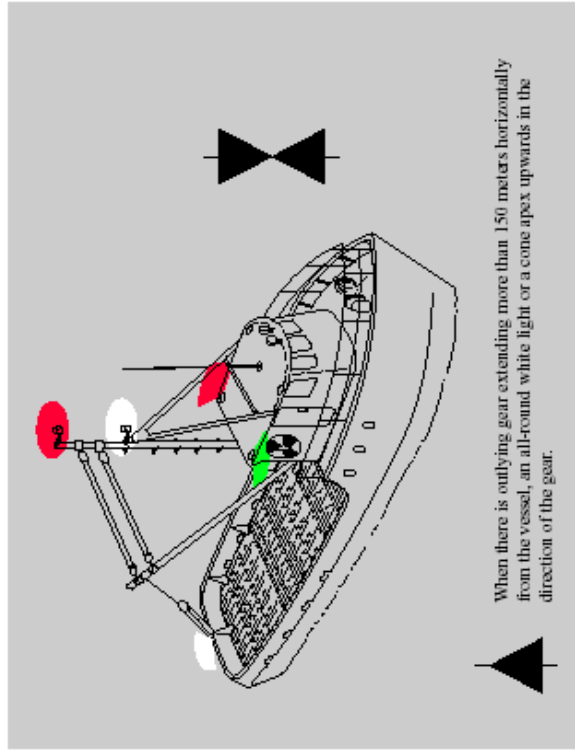

Vessel engaged in fishing other than trawling—making way.
Same for Inland.

—INLAND—

Lights and Shapes

RULE 26—CONTINUED

- (c) A vessel engaged in fishing, other than trawling, shall exhibit:
- (i) two all-round lights in a vertical line, the upper being red and the lower white, or a shape consisting of two cones with apexes together in a vertical line one above the other;
 - (ii) when there is outlying gear extending more than 150 meters horizontally from the vessel, an all-round white light or a cone apex upward in the direction of the gear; and
 - (iii) when making way through the water, in addition to the lights prescribed in this paragraph, sidelights and a sternlight.

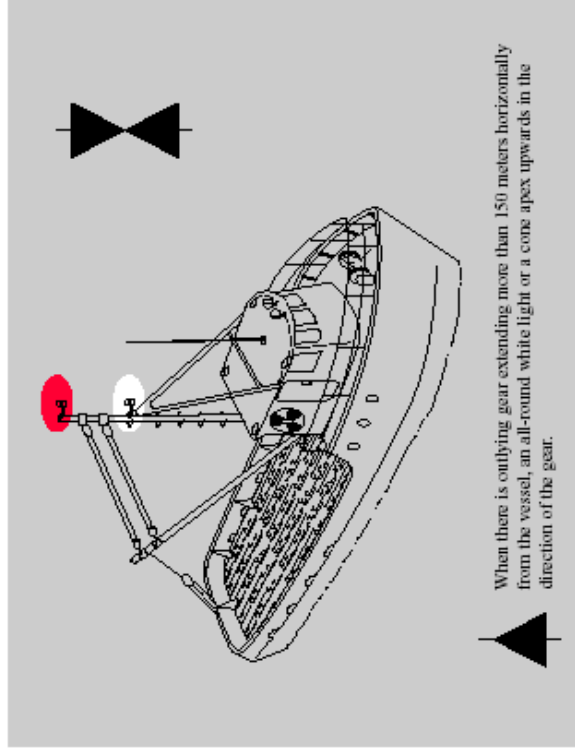

Vessel engaged in fishing other than trawling—not making way.
Same for International.

—INTERNATIONAL—
Lights and Shapes

RULE 26—CONTINUED

- (d) The additional signals described in Annex II to these Rules apply to a vessel engaged in fishing in close proximity to other vessels engaged in fishing.
- (e) A vessel when not engaged in fishing shall not exhibit the lights or shapes prescribed in this Rule, but only those prescribed for a vessel of her length.

—INTERNATIONAL—
Lights and Shapes

RULE 27

Vessels Not Under Command or Restricted in Their Ability to Maneuver

- (a) A vessel not under command shall exhibit:
 - (i) two all-round red lights in a vertical line where they can best be seen;
 - (ii) two balls or similar shapes in a vertical line where they can best be seen;
 - (iii) when making way through the water, in addition to the lights prescribed in this paragraph, sidelights and a sternlight.

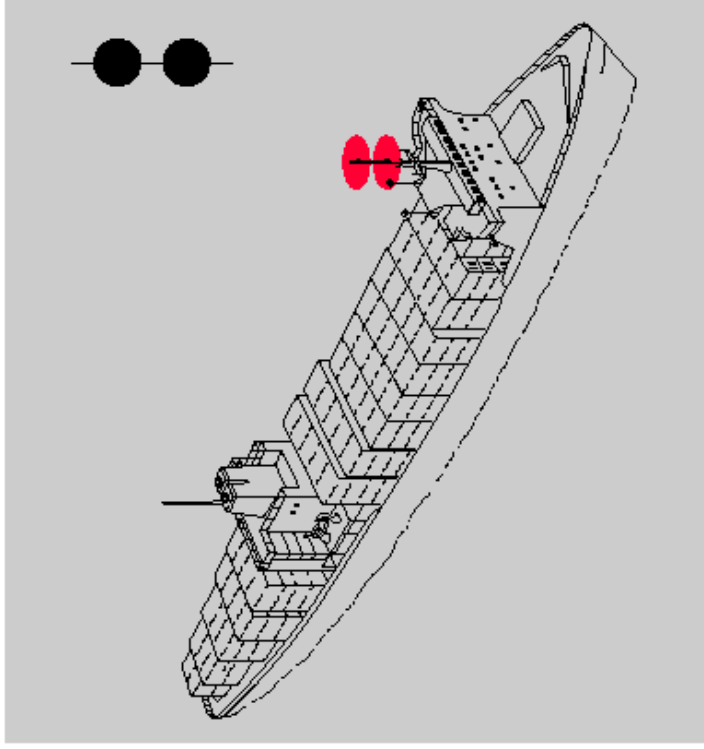

Vessel not under command—not making way. Same for Inland.

—INLAND—

Lights and Shapes

RULE 27

Vessels Not Under Command or Restricted in Their Ability to Maneuver

- (a) A vessel not under command shall exhibit:
- (i) two all-round red lights in a vertical line where they can best be seen;
 - (ii) two balls or similar shapes in a vertical line where they can best be seen; and (iii) when making way through the water, in addition to the lights prescribed in this paragraph, sidelights and a sternlight.

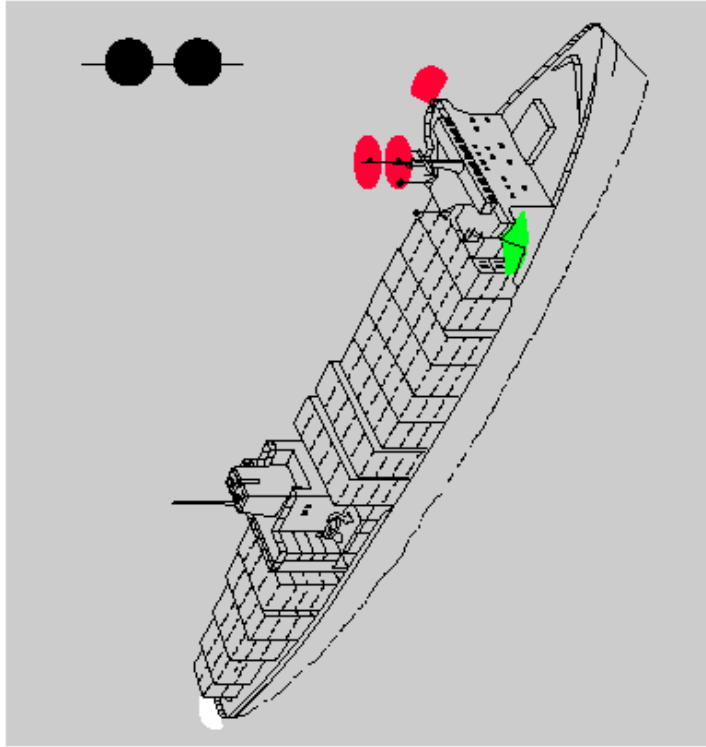

Vessel not under command—making way. Same for International.

—INTERNATIONAL—

Lights and Shapes

RULE 27—CONTINUED

- (b) A vessel restricted in her ability to maneuver, except a vessel engaged in mineclearance operations, shall exhibit:
- (i) three all-round lights in a vertical line where they can best be seen. The highest and lowest of these lights shall be red and the middle light shall be white;
 - (ii) three shapes in a vertical line where they can best be seen. The highest and lowest of these shapes shall be balls and the middle one a diamond;
 - (iii) when making way through the water, a masthead light or lights, sidelights and a sternlight, in addition to the lights prescribed in subparagraph (i);
 - (iv) when at anchor, in addition to the lights or shapes prescribed in subparagraphs (i) and (ii), the light, lights or shape prescribed in Rule 30.

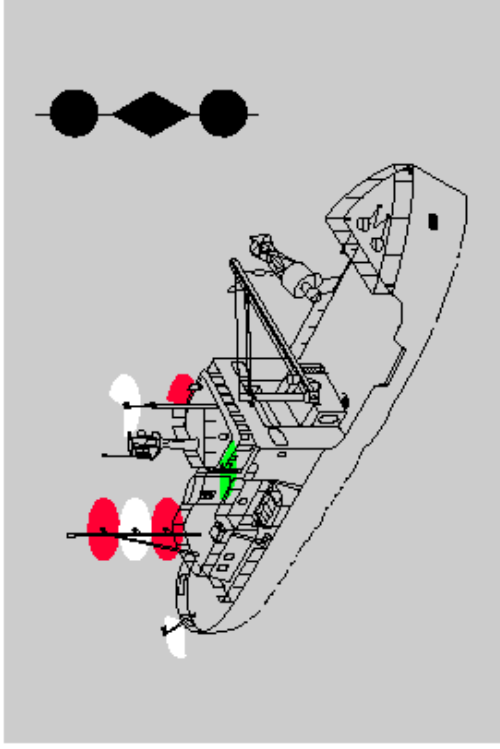

Vessel restricted in her ability to maneuver—making way; vessel less than 50 meters in length. Same for Inland.

—INLAND—

Lights and Shapes

RULE 27—Continued

(b) A vessel restricted in her ability to maneuver, except a vessel engaged in mineclearance operations, shall exhibit:

- (i) three all-round lights in a vertical line where they can best be seen. The highest and lowest of these lights shall be red and the middle light shall be white;
- (ii) three shapes in a vertical line where they can best be seen. The highest and lowest of these shapes shall be balls and the middle one a diamond;
- (iii) when making way through the water, masthead lights, sidelights and a sternlight, in addition to the lights prescribed in subparagraph (b)(i); and
- (iv) when at anchor, in addition to the lights or shapes prescribed in subparagraphs (b)(i) and (ii), the light, lights or shapes prescribed in Rule 30.

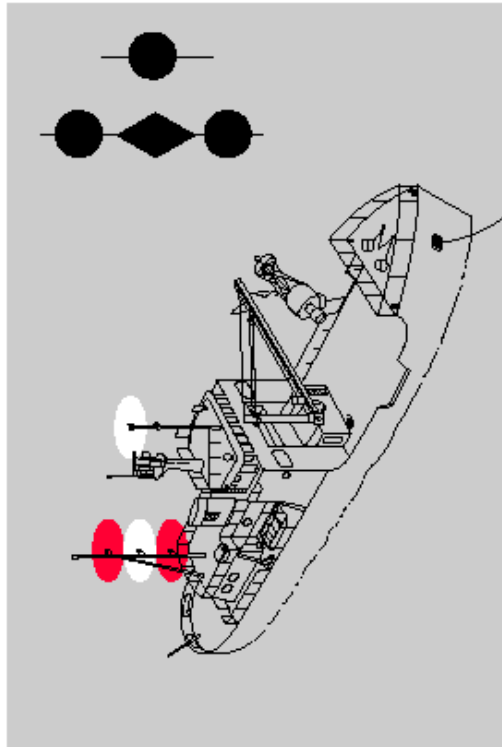

Vessel restricted in her ability to maneuver—at anchor; vessel less than 50 meters in length. Same for International.

—INTERNATIONAL—

Lights and Shapes

RULE 27—CONTINUED

(c) A power-driven vessel engaged in a towing operation such as severely restricts the towing vessel and her tow in their ability to deviate from their course shall, in addition to the lights or shapes prescribed in Rule 24(a), exhibit the lights or shapes prescribed in subparagraphs (b)(i) and (ii) of this Rule.

—INLAND—

Lights and Shapes

RULE 27—CONTINUED

(c) A vessel engaged in a towing operation which severely restricts the towing vessel and her tow in their ability to deviate from their course shall, in addition to the lights or shapes prescribed in subparagraphs (b)(i) and (ii) of this Rule, exhibit the lights or shape prescribed in Rule 24.

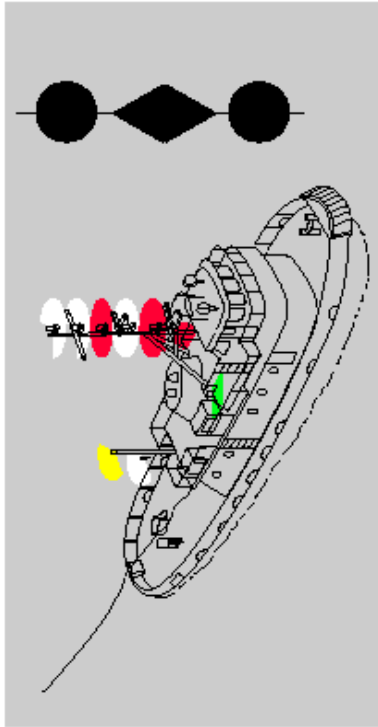

Vessel engaged in towing operation which severely restricts towing vessel and her tow in their ability to deviate from their course—length of tow does not exceed 200 meters; towing vessel less than 50 meters in length. Same for International.

—INTERNATIONAL—

Lights and Shapes

RULE 27—CONTINUED

(d) A vessel engaged in dredging or underwater operations, when restricted in her ability to maneuver, shall exhibit the lights and shapes prescribed in subparagraphs (b)(i), (ii) and (iii) of this Rule and shall in addition, when an obstruction exists, exhibit:

- (i) two all-round red lights or two balls in a vertical line to indicate the side on which the obstruction exists;
- (ii) two all-round green lights or two diamonds in a vertical line to indicate the side on which another vessel may pass;
- (iii) when at anchor, the lights or shapes prescribed in this paragraph instead of the lights or shape prescribed in Rule 30.

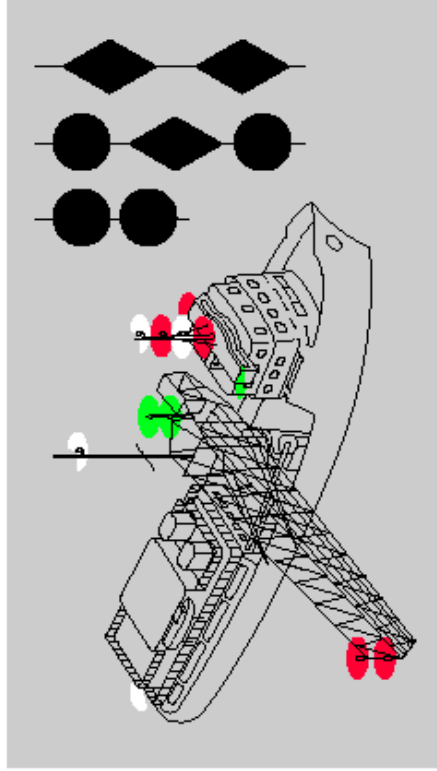

Vessel engaged in dredging or underwater operations when restricted in ability to maneuver—making way with an obstruction on the starboard side. Same for Inland.

—INLAND—
Lights and Shapes

RULE 27—CONTINUED

(d) A vessel engaged in dredging or underwater operations, when restricted in her ability to maneuver, shall exhibit the lights and shapes prescribed in subparagraphs (b)(i), (ii), and (iii) of this Rule and shall in addition, when an obstruction exists, exhibit:

- (i) two all-round red lights or two balls in a vertical line to indicate the side on which the obstruction exists;
- (ii) two all-round green lights or two diamonds in a vertical line to indicate the side on which another vessel may pass; and
- (iii) when at anchor, the lights or shape prescribed by this paragraph, instead of the lights or shapes prescribed in Rule 30 for anchored vessels.

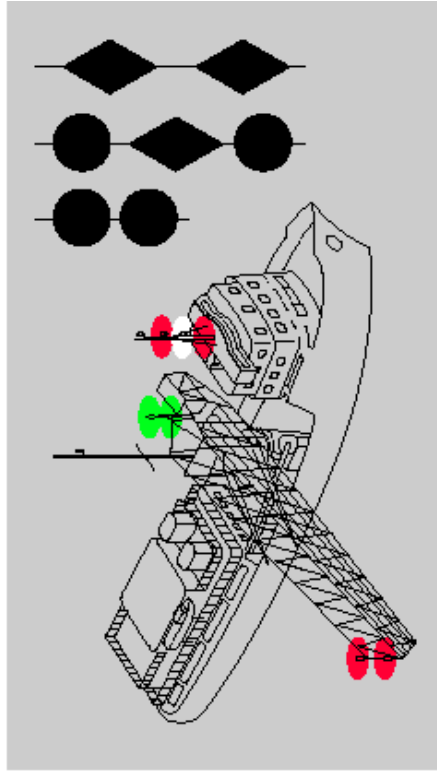

Vessel engaged in dredging or underwater operations when restricted in ability to maneuver—not making way with an obstruction on the starboard side. Same for International.

—INTERNATIONAL—
Lights and Shapes

RULE 27—CONTINUED

(e) Whenever the size of a vessel engaged in diving operations makes it impracticable to exhibit all lights and shapes prescribed in paragraph (d) of this Rule, the following shall be exhibited:

- (i) three all-round lights in a vertical line where they can best be seen. The highest and lowest of these lights shall be red and the middle light shall be white;
- (ii) a rigid replica of the International Code flag "A" not less than 1 meter in height. Measures shall be taken to ensure its all-round visibility.

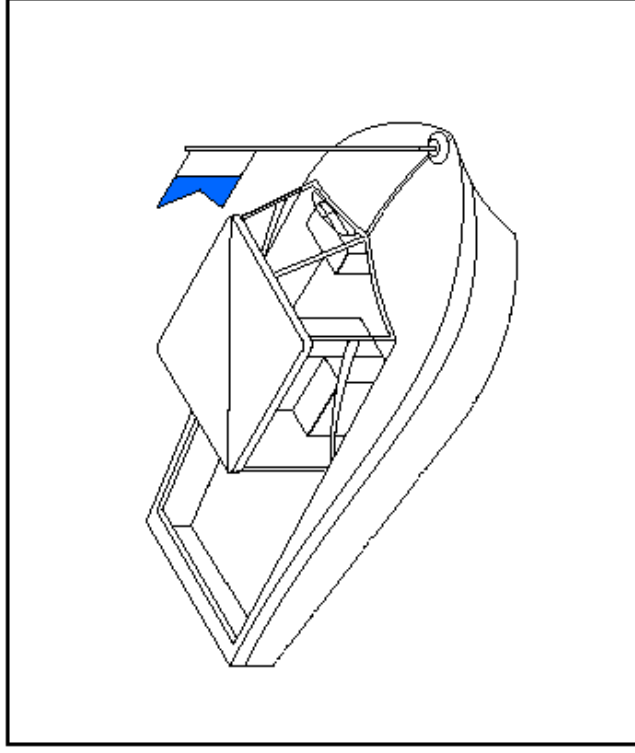

Small vessel engaged in diving operations. Same for Inland.

—INLAND—
Lights and Shapes

RULE 27—CONTINUED

(e) Whenever the size of a vessel engaged in diving operations makes it impracticable to exhibit all lights and shapes prescribed in paragraph (d) of this Rule, the following shall instead be exhibited:

(i) Three all-round lights in a vertical line where they can best be seen. The highest and lowest of these lights shall be red and the middle light shall be white;

(ii) A rigid replica of the international Code flag "A" not less than 1 meter in height. Measures shall be taken to insure its all-round visibility.

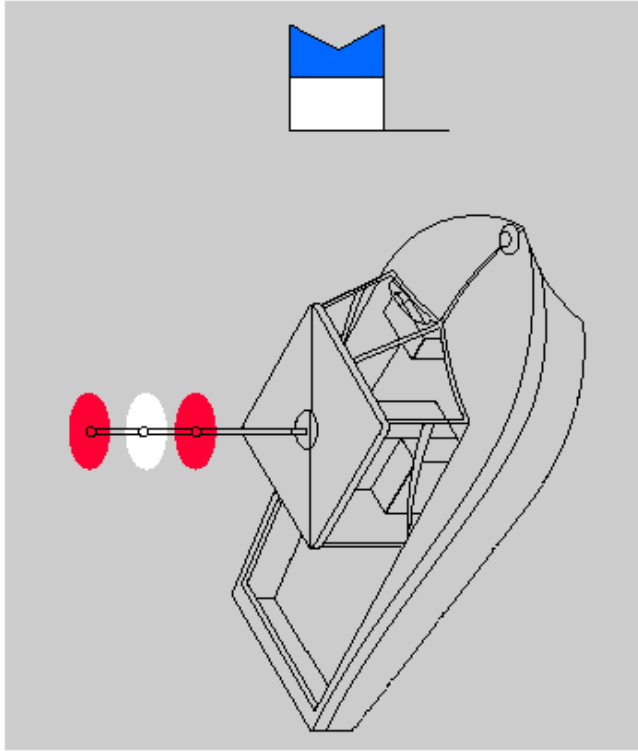

Small vessel engaged in diving operations. Same for International.

—INTERNATIONAL—
Lights and Shapes

RULE 27—CONTINUED

(f) A vessel engaged in mineclearance operations shall, in addition to the lights prescribed for a power-driven vessel in Rule 23 or to the lights or shape prescribed for a vessel at anchor in Rule 30 as appropriate, exhibit three all-round green lights or three balls. One of these lights or shapes shall be exhibited near the foremast head and one at each end of the fore yard. These lights or shapes indicate that it is dangerous for another vessel to approach within 1000 meters of the mineclearance vessel.

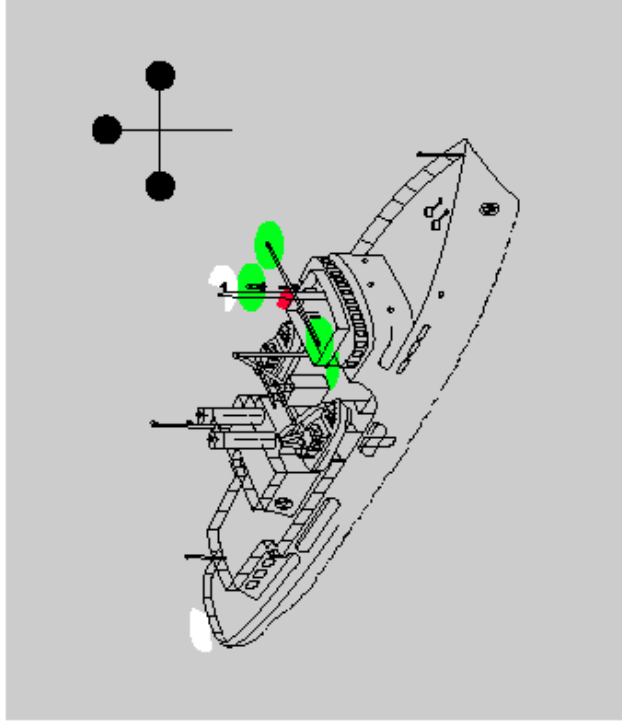

Vessel engaged in mineclearance operations—vessel less than 50 meters in length. Same for Inland.

—INLAND—
Lights and Shapes

RULE 27—CONTINUED

(f) A vessel engaged in mineclearance operations shall, in addition to the lights prescribed for a power-driven vessel in Rule 23 or to the lights or shape prescribed for a vessel at anchor in Rule 30, as appropriate, exhibit three all-round green lights or three balls. One of these lights or shapes shall be exhibited near the foremast head and one at each end of the fore yard. These lights or shapes indicate that it is dangerous for another vessel to approach within 1000 meters of the mineclearance vessel.

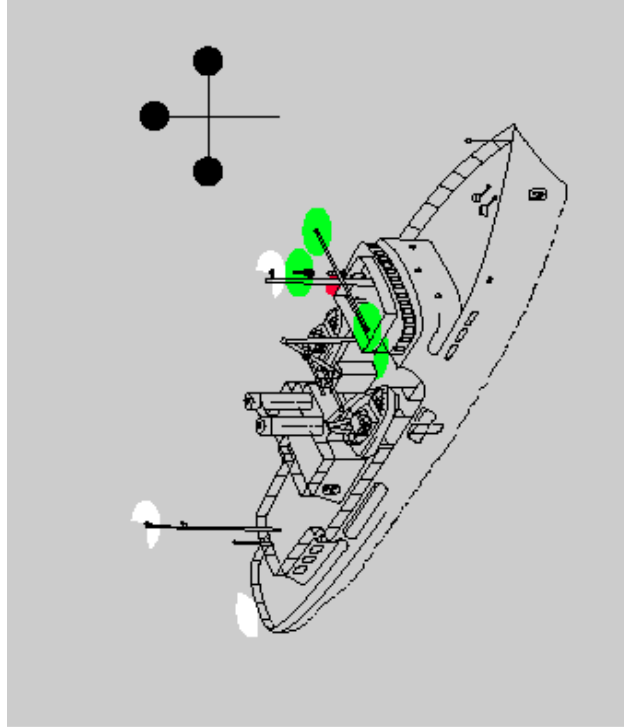

Vessel engaged in mineclearance operations.
Same for International.

—INTERNATIONAL—
Lights and Shapes

RULE 27—CONTINUED

(g) Vessels of less than 12 meters in length, except those engaged in diving operations, shall not be required to exhibit the lights and shapes prescribed in this Rule.
(h) The signals prescribed in this Rule are not signals of vessels in distress and requiring assistance. Such signals are contained in Annex IV to these Regulations.

—INTERNATIONAL—
Lights and Shapes

RULE 28

Vessels Constrained by Their Draft

A vessel constrained by her draft may, in addition to the lights prescribed for power-driven vessels in Rule 23, exhibit where they can best be seen three all-round red lights in a vertical line, or a cylinder. Vessel constrained by her draft.

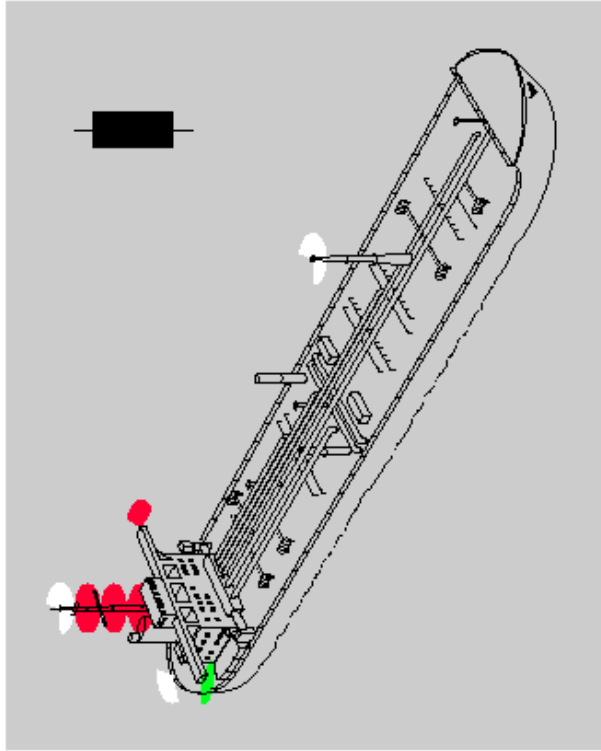

Vessel constrained by her draft.

—INTERNATIONAL—
Lights and Shapes

RULE 29

Pilot Vessels

- (a) A vessel engaged on pilotage duty shall exhibit:
 - (i) at or near the masthead, two all-round lights in a vertical line, the upper being white and the lower red;
 - (ii) when underway, in addition, sidelights and a sternlight;
 - (iii) when at anchor, in addition to the lights prescribed in subparagraph (i), the light, lights or shape prescribed in Rule 30 for vessels at anchor.
- (b) A pilot vessel when not engaged on pilotage duty shall exhibit the lights or shapes prescribed for a similar vessel of her length.

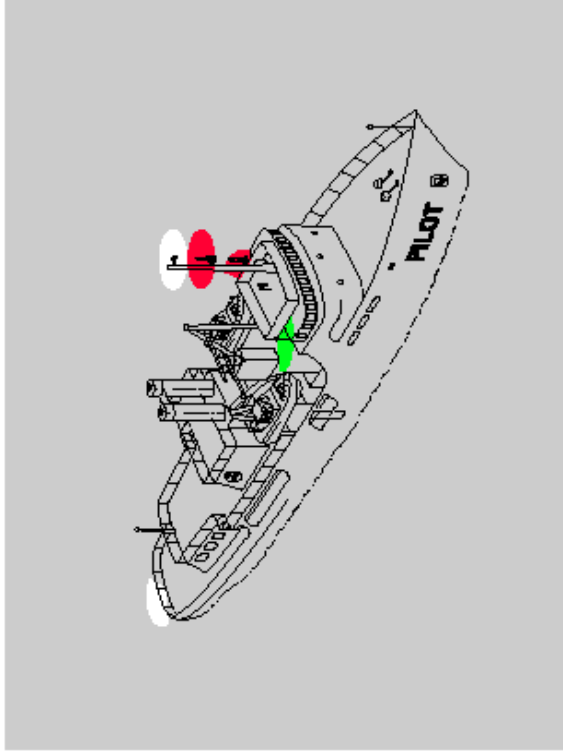

Vessel engaged on pilotage duty—underway. Same for Inland.

—INLAND—
Lights and Shapes

RULE 29
Pilot Vessels

- (a) A vessel engaged on pilotage duty shall exhibit:
- (b) at or near the masthead, two all-round lights in a vertical line, the upper being white and the lower red;
- (i) when underway, in addition, sidelights and a sternlight; and
- (ii) when at anchor, in addition to the lights prescribed in subparagraph (c) (i), the anchor light, lights, or shape prescribed in Rule 30 for anchored vessels.
- (d) A pilot vessel when not engaged on pilotage duty shall exhibit the lights or shapes prescribed for a vessel of her length.

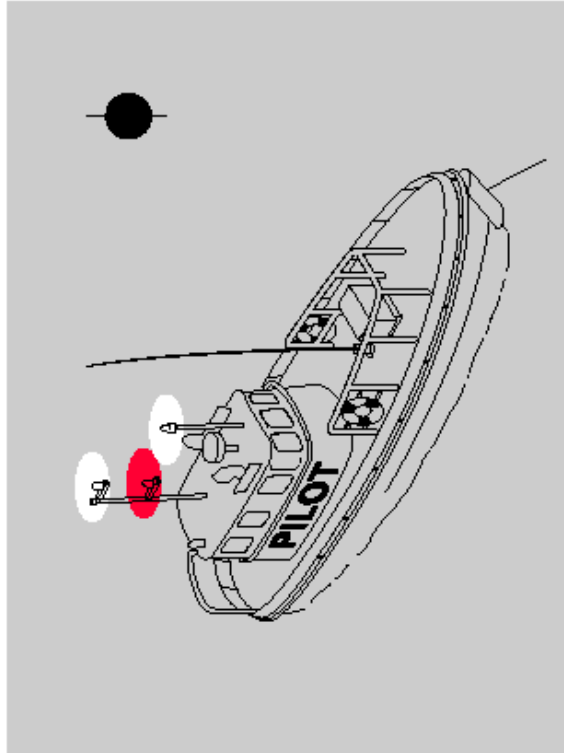

Vessel engaged on pilotage duty—at anchor; vessel of less than 50 meters in length. Same for International.

—INTERNATIONAL—
Lights and Shapes

RULE 30
Anchored Vessels and Vessels Aground

- (a) A vessel at anchor shall exhibit where it can best be seen:
 - (i) in the fore part, an all-round white light or one ball;
 - (ii) at or near the stern and at a lower level than the light prescribed in subparagraph (i), an all-round white light.
- (b) A vessel of less than 50 meters in length may exhibit an all-round white light where it can best be seen instead of the lights prescribed in paragraph (a) of this Rule.
- (c) A vessel at anchor may, and a vessel of 100 meters and more in length shall, also use the available working or equivalent lights to illuminate her decks.

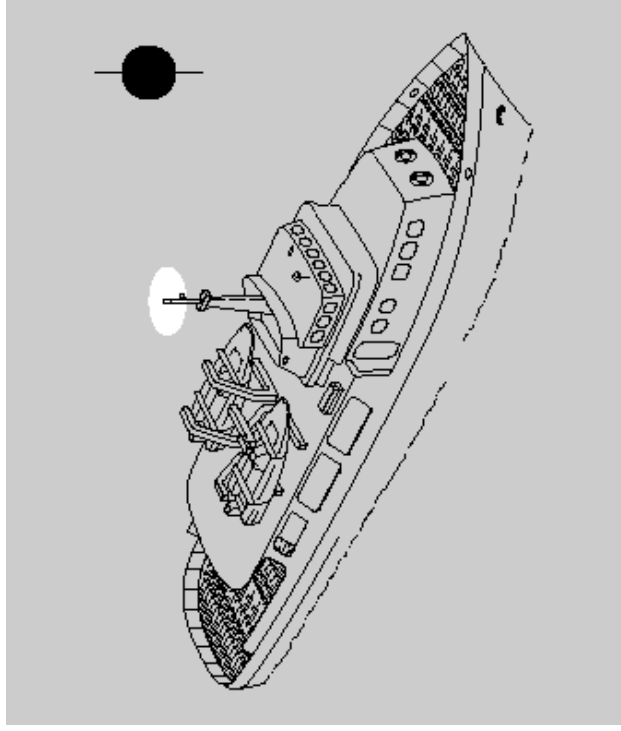

Vessel at anchor—less than 50 meters in length. Same for Inland.

—INLAND—
Lights and Shapes

RULE 30

Anchored Vessels and Vessels Aground

- (a) A vessel at anchor shall exhibit where it can best be seen:
 - (i) in the fore part, an all-round white light or one ball; and
 - (ii) at or near the stern and at a lower level than the light prescribed in subparagraph (i), an all-round white light.
- (b) A vessel of less than 50 meters in length may exhibit an all-round white light where it can best be seen instead of the lights prescribed in paragraph (a) of this Rule.
- (c) A vessel at anchor may, and a vessel of 100 meters or more in length shall, also use the available working or equivalent lights to illuminate her decks.

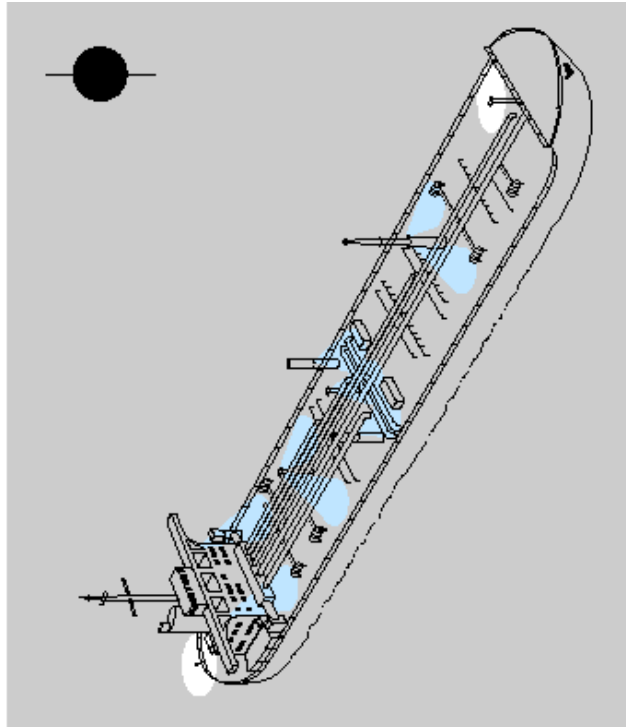

Vessel at anchor with deck illumination. Same for International.

—INTERNATIONAL—
Lights and Shapes

RULE 30—CONTINUED

- (d) A vessel aground shall exhibit the lights prescribed in paragraph (a) or (b) of this Rule and in addition, where they can best be seen:
 - (i) two all-round red lights in a vertical line;
 - (ii) three balls in a vertical line.

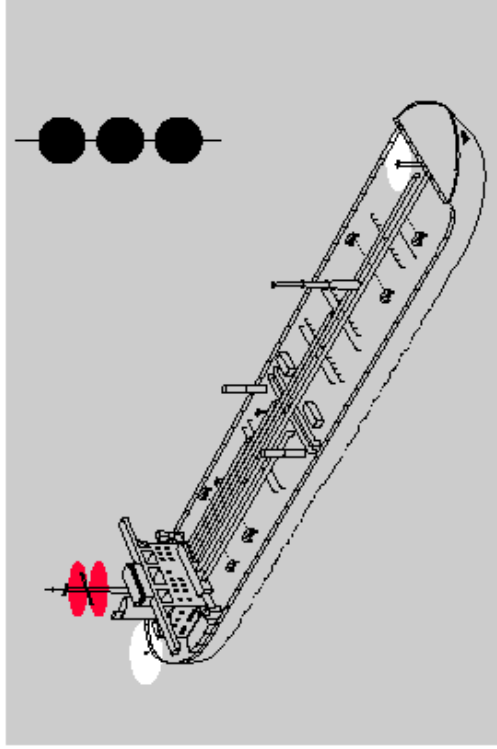

Vessel aground. Same for Inland.

—INLAND—
Lights and Shapes

RULE 30—CONTINUED

- (d) A vessel aground shall exhibit the lights prescribed in paragraph (a) or (b) of this Rule and in addition, if practicable, where they can best be seen:
- (i) two all-round red lights in a vertical line; and
 - (ii) three balls in a vertical line.

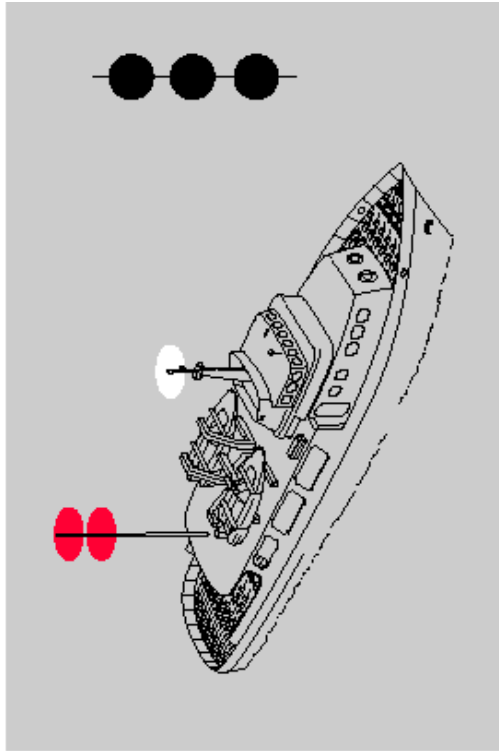

Vessel aground—less than 50 meters in length.
Same for International.

—INTERNATIONAL—
Lights and Shapes

RULE 30—CONTINUED

- (e) A vessel of less than 7 meters in length, when at anchor, not in or near a narrow channel, fairway or anchorage, or where other vessels normally navigate, shall not be required to exhibit the lights or shape prescribed in paragraphs (a) and (b) of this Rule. (f) A vessel of less than 12 meters in length, when aground, shall not be required to exhibit the lights or shapes prescribed in subparagraphs (d)(i) and (ii) of this Rule.

—INTERNATIONAL—

Sound and Light Signals

PART D—SOUND AND LIGHT SIGNALS

RULE 32

Definitions

- (a) The word “whistle” means any sound signaling appliance capable of producing the prescribed blasts and which complies with the specifications in Annex III to these Regulations.
- (b) The term “short blast” means a blast of about one second’s duration.
- (c) The term “prolonged blast” means a blast of from four to six seconds’ duration.

RULE 33

Equipment for Sound Signals

- (a) A vessel of 12 meters or more in length shall be provided with a whistle, a vessel of 20 meters or more in length shall be provided with a bell in addition to a whistle, and a vessel of 100 meters or more in length shall, in addition, be provided with a gong, the tone and sound of which cannot be confused with that of the bell. The whistle, bell and gong shall comply with the specifications in Annex III to these Regulations. The bell or gong or both may be replaced by other equipment having the same respective sound characteristics, provided that manual sounding of the prescribed signals shall always be possible.
- (b) A vessel of less than 12 meters in length shall not be obliged to carry the sound signaling appliances prescribed in paragraph (a) of this Rule but if she does not, she shall be provided with some other means of making an efficient sound signal.

—INTERNATIONAL—

Sound and Light Signals

RULE 34

Maneuvering and Warning Signals

- (a) When vessels are in sight of one another, a power-driven vessel underway, when maneuvering as authorized or required by these Rules, shall indicate that maneuver by the following signals on her whistle:
 - one short blast to mean “I am altering my course to starboard”;
 - two short blasts to mean “I am altering my course to port”;
 - three short blasts to mean “I am operating astern propulsion”.
- (b) Any vessel may supplement the whistle signals prescribed in paragraph (a) of this Rule by light signals, repeated as appropriate, while the maneuver is being carried out:
 - (i) these light signals shall have the following significance:
 - one flash to mean “I am altering my course to starboard”;
 - two flashes to mean “I am altering my course to port”;
 - three flashes to mean “I am operating astern propulsion”;
 - (ii) the duration of each flash shall be about one second, the interval between flashes shall be about one second, and the interval between successive signals shall be not less than ten seconds;
 - (iii) the light used for this signal shall, if fitted, be an all-round white light, visible at a minimum range of 5 miles, and shall comply with the provisions of Annex I to these Regulations.

—INTERNATIONAL—

Sound and Light Signals

RULE 34—CONTINUED

- (c) When in sight of one another in a narrow channel or fairway:
- (i) a vessel intending to overtake another shall in compliance with Rule 9(e)(i) indicate her intention by the following signals on her whistle:
 - two prolonged blasts followed by one short blast to mean “I intend to overtake you on your starboard side”;
 - two prolonged blasts followed by two short blasts to mean “I intend to overtake you on your port side”.
 - (ii) the vessel about to be overtaken when acting in accordance with Rule 9(e)(i) shall indicate her agreement by the following signal on her whistle:
 - one prolonged, one short, one prolonged and one short blast, in that order.
- (d) When vessels in sight of one another are approaching each other and from any cause either vessel fails to understand the intentions or actions of the other, or is in doubt whether sufficient action is being taken by the other to avoid collision, the vessel in doubt shall immediately indicate such doubt by giving at least five short and rapid blasts on the whistle. Such signal may be supplemented by a light signal of at least five short and rapid flashes.
- (e) A vessel nearing a bend or an area of a channel or fairway where other vessels may be obscured by an intervening obstruction shall sound one prolonged blast. Such signal shall be answered with a prolonged blast by any approaching vessel that may be within hearing around the bend or behind the intervening obstruction.
- (f) If whistles are fitted on a vessel at a distance apart of more than 100 meters, one whistle only shall be used for giving maneuvering and warning signals.

—INTERNATIONAL—

Sound and Light Signals

RULE 35

Sound Signals in Restricted Visibility

In or near an area of restricted visibility, whether by day or night, the signals prescribed in this Rule shall be used as follows:

- (a) A power-driven vessel making way through the water shall sound at intervals of not more than 2 minutes one prolonged blast.
- (b) A power-driven vessel underway but stopped and making no way through the water shall sound at intervals of not more than 2 minutes two prolonged blasts in succession with an interval of about 2 seconds between them.
- (c) A vessel not under command, a vessel restricted in her ability to maneuver, a vessel constrained by her draft, a sailing vessel, a vessel engaged in fishing and a vessel engaged in towing or pushing another vessel shall, instead of the signals prescribed in paragraphs (a) or (b) of this Rule, sound at intervals of not more than 2 minutes three blasts in succession, namely one prolonged followed by two short blasts.
- (d) A vessel engaged in fishing, when at anchor, and a vessel restricted in her ability to maneuver when carrying out her work at anchor, shall instead of the signals prescribed in paragraph (g) of this Rule sound the signal prescribed in paragraph (c) of this Rule.
- (e) A vessel towed or if more than one vessel is towed the last vessel of the tow, if manned, shall at intervals of not more than 2 minutes sound four blasts in succession, namely one prolonged followed by three short blasts. When practicable, this signal shall be made immediately after the signal made by the towing vessel.
- (f) When a pushing vessel and a vessel being pushed ahead are rigidly connected in a composite unit they shall be regarded as a power-driven vessel and shall give the signals prescribed in paragraphs (a) or (b) of this Rule.

—INTERNATIONAL—
Sound and Light Signals

RULE 35—CONTINUED

(g) A vessel at anchor shall at intervals of not more than one minute ring the bell rapidly for about 5 seconds. In a vessel of 100 meters or more in length the bell shall be sounded in the forepart of the vessel and immediately after the ringing of the bell the gong shall be sounded rapidly for about 5 seconds in the after part of the vessel. A vessel at anchor may in addition sound three blasts in succession, namely one short, one prolonged and one short blast, to give warning of her position and of the possibility of collision to an approaching vessel.

(h) A vessel aground shall give the bell signal and if required the gong signal prescribed in paragraph (g) of this Rule and shall, in addition, give three separate and distinct strokes on the bell immediately before and after the rapid ringing of the bell. A vessel aground may in addition sound an appropriate whistle signal.

(i) A vessel of 12 meters or more but less than 20 meters in length shall not be obliged to give the bell signals prescribed in paragraphs (g) and (h) of this Rule. However, if she does not, she shall make some other efficient sound signal at intervals of not more than 2 minutes.

(j) A vessel of less than 12 meters in length shall not be obliged to give the above-mentioned signals but, if she does not, shall make some other efficient sound signal at intervals of not more than 2 minutes.

(k) A pilot vessel when engaged on pilotage duty may in addition to the signals prescribed in paragraphs (a), (b) or (g) of this Rule sound an identity signal consisting of four short blasts.

—INTERNATIONAL—
Sound and Light Signals

RULE 36

Signals to Attract Attention

If necessary to attract the attention of another vessel, any vessel may make light or sound signals that cannot be mistaken for any signal authorized elsewhere in these Rules, or may direct the beam of her searchlight in the direction of the danger, in such a way as not to embarrass any vessel. Any light to attract the attention of another vessel shall be such that it cannot be mistaken for any aid to navigation. For the purpose of this Rule the use of high intensity intermittent or revolving lights, such as strobe lights, shall be avoided.

—INTERNATIONAL—

















Sound and Light Signals

RULE 37

Distress Signals

When a vessel is in distress and requires assistance she shall use or exhibit the signals described in Annex IV to these Regulations.

DISTRESS SIGNALS 72 COLREGS

 RED STAR SHELLS	 GUN FIRED AT INTERVALS OF 1 MIN.	 PARACHUTE RED FLARE	 WAVE ARMS	 SMOKE
 FLAMES ON A VESSEL	 "MAYDAY" BY RADIO	 SQUARE FLAG AND BALL	 POSITION INDICATING RADIO BEACON	
 FOG HORN CONTINUOUS SOUNDING	 SOS	 CODE FLAGS NOVEMBER CHARLIE	 RADIO TELEPHONE ALARM	
 ORANGE BACKGROUND BLACK BALL AND SQUARE	 DYE MARKER (ANY COLOR)	 RADIO-TELEGRAPH ALARM		

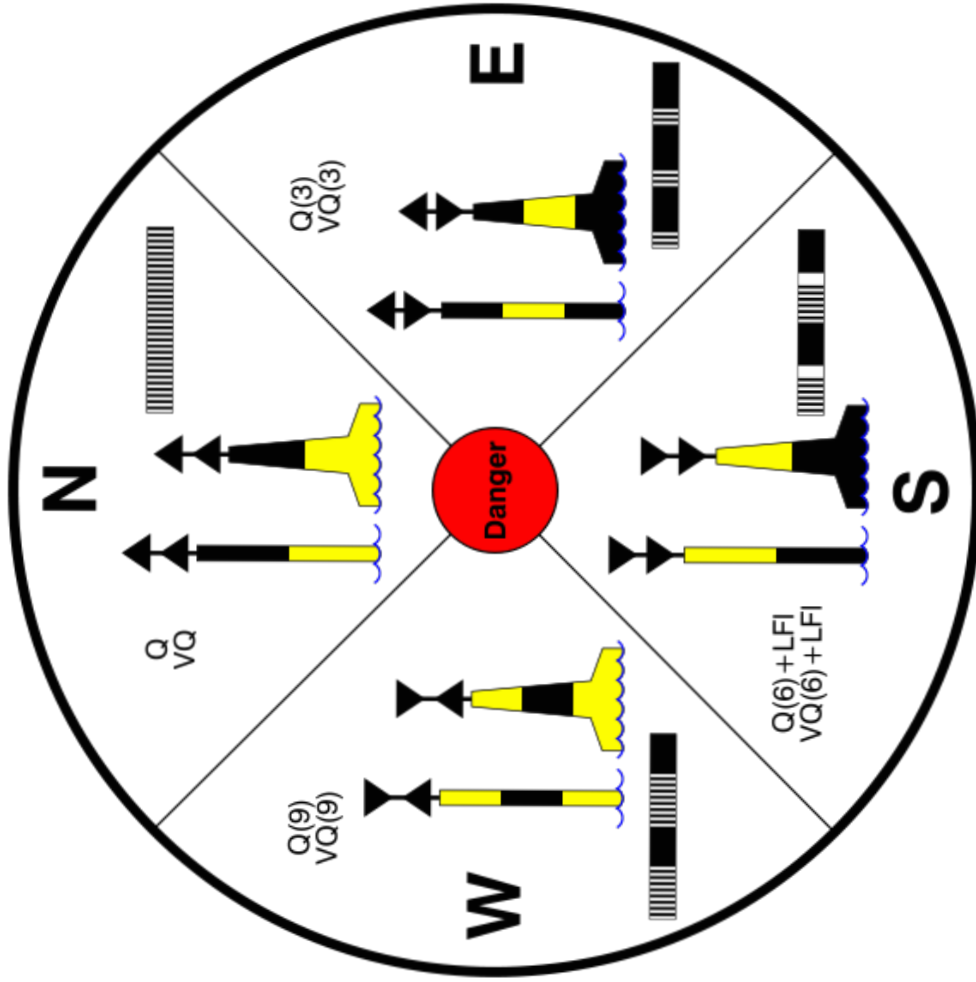

Rules of the Road Situations

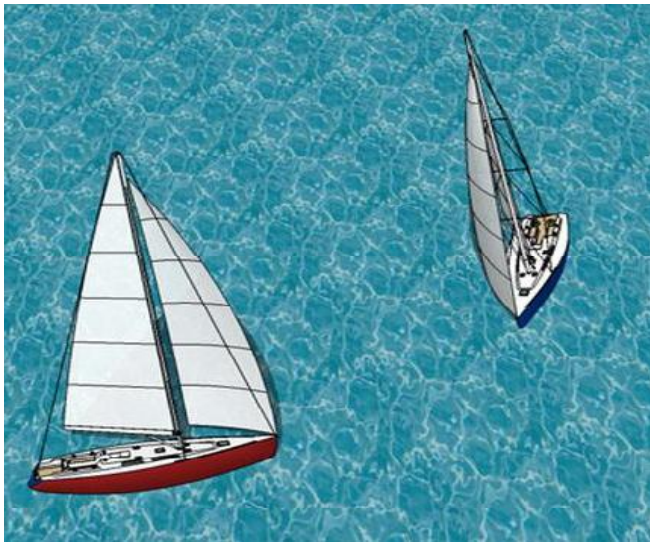

2 sailing vessels: starboard tack stands on



2 sailing vessels: windward gives way



Overtaking: overtaking vessel gives way



Sail vs. Power: power vessel gives way



Power vs. Power: vessel to starboard stands on



Power vs. Power: vessel to starboard stands on

Rules of the Road - Navigation lights

Light	Arc	Color	Visible Range
Masthead Light	225°	White	2
Starboard Sidelight	112.5°	Green	1
Port Sidelight	112.5°	Red	1
Sternlight	135°	White	2

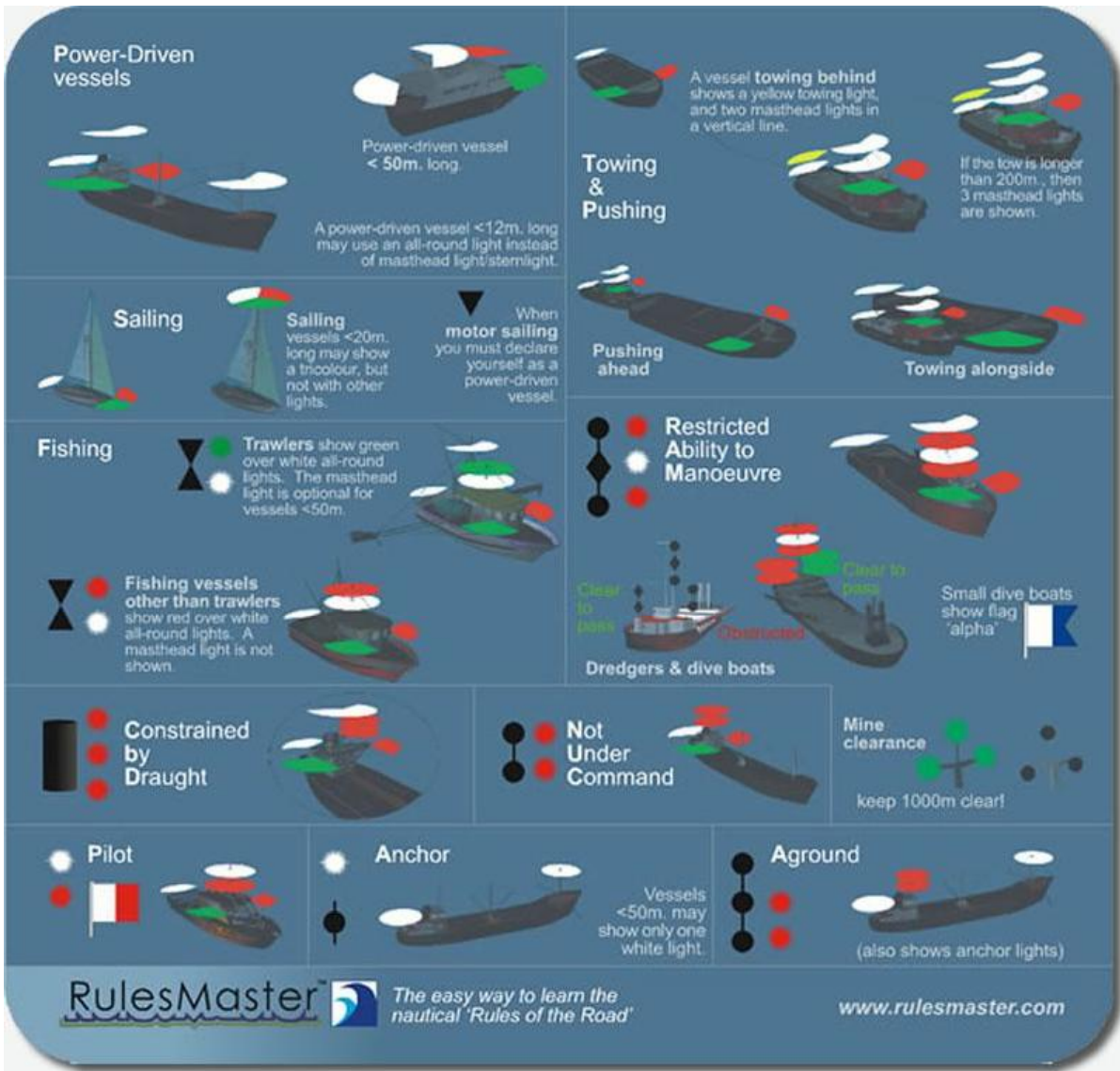
Power-Driven vessels

Power-driven vessel < 50m. long

A power-driven vessel < 12m. long may use an all-round light instead of masthead light/sternlight.

Towing & Pushing

A vessel towing behind shows a yellow towing light, and two masthead lights in a vertical line.

If the tow is longer than 200m., then 3 masthead lights are shown.

Sailing

Sailing vessels < 20m. long may show a tricolour, but not with other lights.

When motor sailing you must declare yourself as a power-driven vessel.

Fishing

Trawlers show green over white all-round lights. The masthead light is optional for vessels < 50m.

Fishing vessels other than trawlers show red over white all-round lights. A masthead light is not shown.

Restricted Ability to Manoeuvre

Clear to pass (Red over Green)

Obstructed (Red over White)

Small dive boats show flag 'alpha'

Dredgers & dive boats

Constrained by Draught

Not Under Command

Mine clearance

keep 1000m clear!

Pilot

Anchor

Vessels < 50m. may show only one white light.

Aground

(also shows anchor lights)

RulesMaster The easy way to learn the nautical 'Rules of the Road'

www.rulesmaster.com

Rules of the Road - Navigation lights

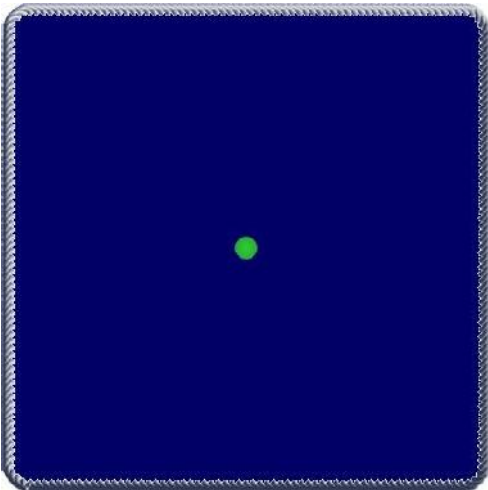

Type of Vessel: _____
 Aspect of Vessel: _____
 Length of Vessel: _____

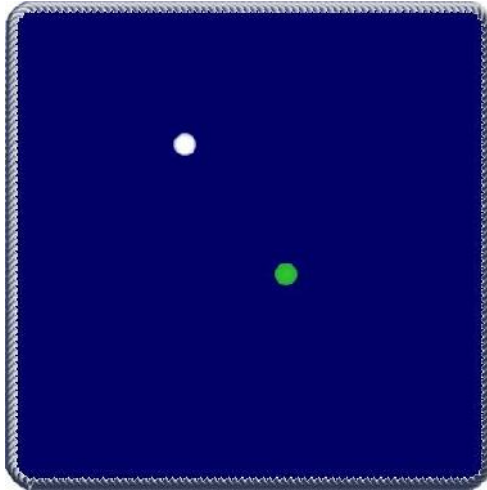

Type of Vessel: _____
 Aspect of Vessel: _____
 Length of Vessel: _____

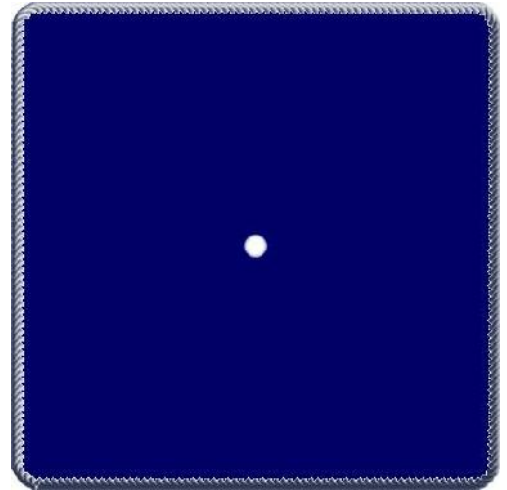

Type of Vessel: _____
 Aspect of Vessel: _____
 Length of Vessel: _____

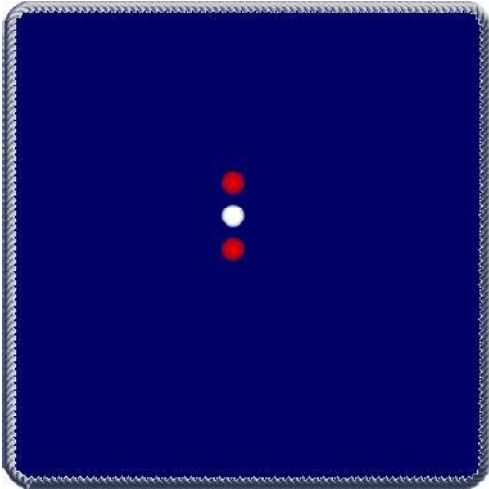

Type of Vessel: _____
 Aspect of Vessel: _____
 Length of Vessel: _____

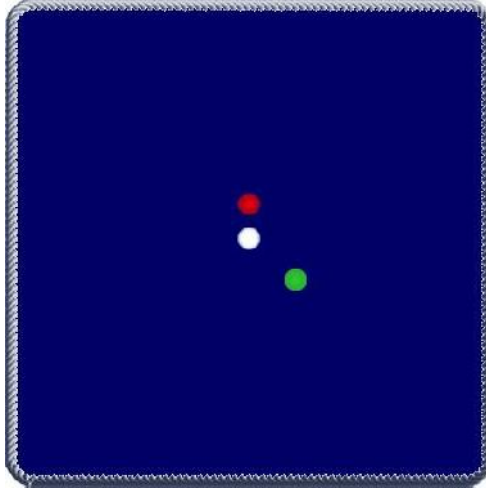

Type of Vessel: _____
 Aspect of Vessel: _____
 Length of Vessel: _____

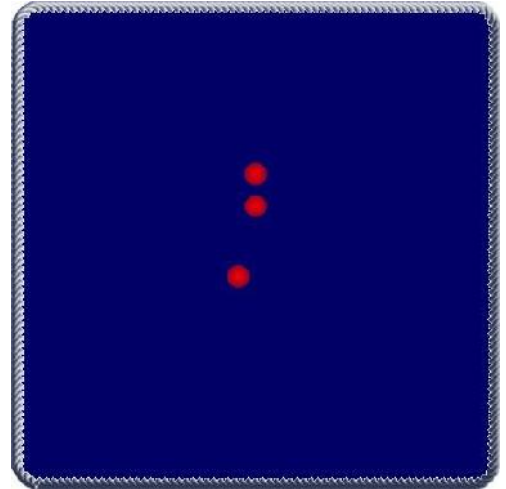

Type of Vessel: _____
 Aspect of Vessel: _____
 Length of Vessel: _____

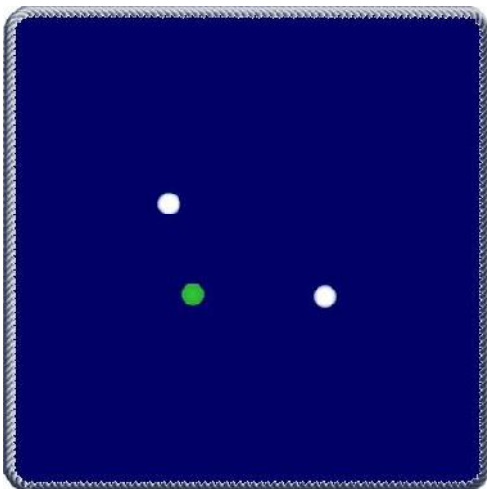

Type of Vessel: _____
 Aspect of Vessel: _____
 Length of Vessel: _____



Type of Vessel: _____
 Aspect of Vessel: _____
 Length of Vessel: _____



Type of Vessel: _____
 Aspect of Vessel: _____
 Length of Vessel: _____